

Build Your Own Custom Luggage Trunk

The time is within the memory of many of us when any surplus baggage a motorist might care to take along was either piled in the tonneau of his motor car or strapped on the running boards. We have seen automobiles rolling down the pike with a set of bedsprings and a feather tick lashed securely to the top deck. Once we saw a tourist car with a crate built onto one running board. In the crate stood a yearling colt, and the Ford spun merrily along.

The picture is changing. Where once emergency tools were carried under the rear seat and on the occasion of the hourly puncture passengers were invited to dismount, now we have hidden tool compartments here and there and the passengers remain seated. Under the floor, beneath the motor hood, countersunk in the splash pan along the side, the tools are out of sight, out of the way, yet instantly available in time of need.

Then for the cross-country tourist; once a part of the standard equipment for a vacation trip was a pair of luggage racks to be clamped to the running boards. Most of them were collapsible, some purposely, others accidentally. When the trip began, these unsightly contrivances were extended, loaded full of this and that and whatnot, and the passengers, heaven help them, had to crawl and climb all over the heterogenous collection every time they entered or left the car.

We live; we learn. We have found that all this nuisance and bother are avoidable—and we're avoiding it. Where the family once took along a ten-by twelve foot wall tent, with ridge-pole and three uprights, they now, more often than not, carry an umbrella type tent that uses one collapsible pole, gives fully as much floor space when set up, but is made of balloon silk or some other like fabric. The old-time tent of twelve-ounce cotton duck almost required a trailer. The modern lightweight tent, fully as water-proof as its granddaddy, could be packed in the average suitcase.

Too, with the growing popularity of the cottage campground, fewer people are using tents. They drive from point to point, stopping every night in a clean little cabin with a good bed, hot and cold running water, an electric plate for cooking and almost every other convenience of home. It is only the first-time tourist who goes via the "sagebrush route" nowadays. The old-timers have learned better.

All of which is by the way of saying that the new demand for custom-built luggage trunks is not just something out of the sky. It is the result of a logical development. The cross-country tourist nowadays wants some place where he can pack his suitcases and his fishing tackle without having them in the way of the occupants of the car. When he gets back to the city he wants space to store bundles when he goes down town shopping. Above all, he wants that someplace to be decorative in appearance, to harmonize with the lines and color scheme of his automobile, to be a source of pride and joy. And he will pay your price for it. That has been shown by practical demonstration.

The advent of the new Ford alone brought about the establishment of a hundred or more little factories for building luggage trunks for that car, so-called custom-built trunks to harmonize with the new lines and color schemes. If you doubt that statement, glance through the advertising section of any magazine devoted to Fords, their owners and their problems. *The Automobile Trimmer and Painter*, July 1929.

by MARSHALL LEWIS
and LORIN SORENSEN

NOW that you have moved the spare tire from the rear to the front fender (*Installing Fender Wells*—an article in the last issue) you have room for a luggage rack and trunk. The custom-built luggage trunk is one era accessory that is becoming more a necessity than an interesting gadget these days as Model A's venture farther away from home in search of road adventure for their owners. Here's how to build your own.

Words written nearly a half-century ago when the Model A was but a babe in the woods, these comments are as appropriate now as then. The distinguishing traits of the old Ford have not changed with the passage of time—only the circumstances.

Touring is the primary use of the restored Model A and whether it's a short trip around the adjacent countryside or a cross-country jaunt, there is always that problem of what to do with excess baggage, spare parts, car covers, tools and picnic supplies. The luggage trunk is the solution as it not only makes stowables far more accessible but adds to the smartness of the car and the restoration.

But where does a restorer get a custom luggage trunk that doesn't cost an arm and a leg through the trade periodicals, swap meets etc.?

The answer. Make it yourself with a few simple tools!

John Stewart MacClary authored the words of wisdom heading this article in a feature written for the July, 1929, issue of *The Automobile Trimmer and Painter*. The article, entitled *Custom-built Luggage Trunks* went on to describe how the Model A Ford owner of that era could make his own trunk using materials obtained from the lumber yard and hardware store. The author included some sketches to help the handyman.

To test the actual application of MacClary's instructions we called on master Model A restorer, Marshall Lewis, of Empire, California, to follow the plans and build a luggage trunk that would fit any Model A Ford. Lewis was to improve on the plan where possible and to keep an accounting of the costs of materials used, tools needed and modern developments which have made some of the 1929 construction methods obsolete.

Basically as written, but with a number of modifications by Lewis, MacClary's *Custom-built Luggage Trunks* article is as follows:

Materials

The materials used in the construction of custom-built luggage trunks are neither expensive nor hard to procure. The foundation materials for building the bare trunk are available in any community (Handi-man Stores, K-Mart, large hardware stores etc.) The covering materials can be procured from a well-stocked auto upholstery shop and the leather trim, while scarce, from a saddle or leathercraft shop.

—continued on page 10—

There are two principle parts in the luggage trunk assembly; the luggage trunk proper, and the trunk rack on which the trunk is mounted. The rack is an accessory that comes in many forms from many manufacturers and is an item that will not be discussed in this article other than to caution the builder to measure his rack before settling on the final dimensions of the luggage trunk he will construct to fit it. It is to be assumed that the builder has a rack for his car before he starts the project.

The materials needed for building the trunk alone consist briefly of a good grade of exterior plywood, strap leather, lining material, covering material, hinges and toggle locks, glue, screws and tacks.

Trunk For Model A Tudor Sedan

(The MacClary article describes the building of a luggage trunk 34" wide and contoured to the back of a 1929 Model A Tudor. Using this plan as a basis, Lewis built a universal type 31" wide as seen in the sketch on page 11 without the form fit).

Figure 1 presents the front view of the trunk when completed, naming the view which greets the eye when standing behind the car as the front. Overall dimensions are included in the drawing, and all parts and fittings are labeled.

It will be observed that the trunk is thirty-four inches in length, over-all; and eighteen inches in height. Two toggle latches are used and a central lock is provided. If it is possible to obtain toggle latches which include locks, so much the better. (These are available in the stocks of some 1974-era luggage supply houses.) The toggle latch should also include a lift or hook which aids in opening the lid of the trunk.

Each corner of the trunk is reinforced and covered by a patch of strap leather, tacked to the trunk structure. Two wide leather straps with buckles aid in setting off the job as a bit of custom work but are strictly for looks and have no real function. The toggle latches actually serve to link the lid and trunk securely. (For nostalgic reasons and to make it "look right" the smart leather straps are a must).

Figure 2 presents the right-end view of the complete trunk. Here the joint between lid and trunk is shown, as is also the split leather corner at the rear which permits the hinge action of the lid when opened. It will be observed that the trunk lid is five inches deep at the front, tapering to but two inches in depth at the back. A detail view of this trunk lid end will be presented further on in the article.

In this same figure the contour of the trunk where it follows the line of the tonneau back is indicated. A method and a scale for determining this contour are supplied later in this discussion. The leather strap end-lift is also shown. It is used in lifting the trunk onto and off the rack, and also serves a decorative purpose. It is held to the trunk by two riveted keepers, indicated in the drawing.

The toggle latch and hooked lid lift are shown in outline. The heavy straps and buckles seen in Figure 1 are shown in Figure 2 by heavy black lines around the top of the lid and along the front of the trunk proper.

Figure 3 shows the top view of the trunk and lid as from the same viewpoint as Figure 1. The two wide straps, with their keepers, the end lifts shown in Figure 2, the toggle latches, curving forepart of the lid and curving back of the trunk are all indicated. These three figures, 1, 2 and 3, show the trunk as when completed. Figure 4 shows the installation of the trunk on a Model "A" Ford Tudor Sedan, trunk, rack and all.

Figures 5, 6 and 7 give plan views of a luggage trunk rack or platform. (The 1974 restorer will do better to obtain the rack of his choice from a current supplier).

Construction of the Trunk Body

The outline of the back of the trunk follows closely the

contour of the rear tonneau panel of the car body. The space which will exist between the car body and the trunk is about two inches. The scale shown in Figure 8 will serve as a guide for the 1929 Model A Ford Tudor Sedan. For other models a

-continued on page 12-

MATERIALS NECESSARY TO BUILD YOUR OWN LUGGAGE TRUNK

| Item | Cost |
|--|---------|
| Genuine leather (for straps & corners) | \$14.00 |
| 1½ yards leatherette (lining) | 4.00 |
| 30-inch piano hinge | 2.50 |
| 1/8-inch exterior plywood | 1.00 |
| 1/4-inch exterior plywood | 1.80 |
| 5/8-inch exterior plywood | 3.20 |
| One small Elmer's Glue | .59 |
| One can Contact Spray Glue | 3.50 |
| One roll 1/8 x 5/8 weatherstrip | .89 |
| 1½ yards landau top material | 7.50 |
| Nails | .20 |
| Screws | .80 |
| Tacks (for corners) | 2.30 |
| Two buckles with locks | 4.00 |
| One lid stay | 1.50 |
| Four handle loops | .80 |
| | \$48.58 |

TOOLS NEEDED

| | |
|---------------------|-----------------------|
| Hand saw | Hammer |
| Four small clamps | Screw driver |
| One furniture clamp | 2-foot square |
| Wood rasp | ¼-inch electric drill |
| Sanding block | Staple gun |

LUGGAGE TRUNK HARDWARE SOURCES

Luggage & Handbag Supply
1216 W. Olympic
Los Angeles, Calif. (Large supply—\$20 minimum)

Joseph Hart & Son
16 Reade St.
New York 17, N.Y. (Mostly wholesale)

Ohio Traveling Bag Co.
811 Prospect Ave.
Cleveland, Ohio

A.E. Meek Trunk & Bag Co.
1544 Broadway
Denver, Colorado (no catalogue available)

Dayton Carrier Co.
2040 Little York Road
Dayton, Ohio

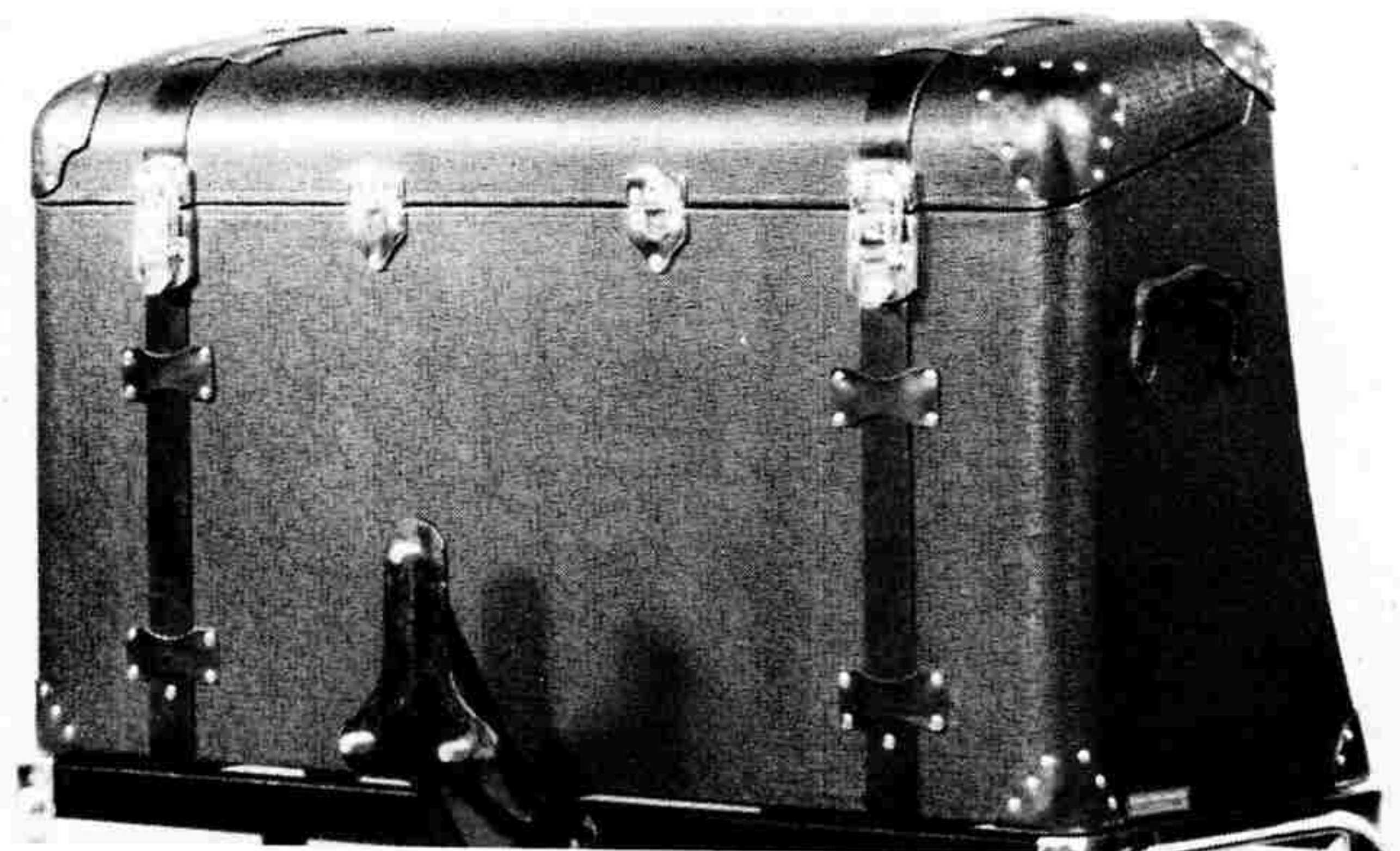

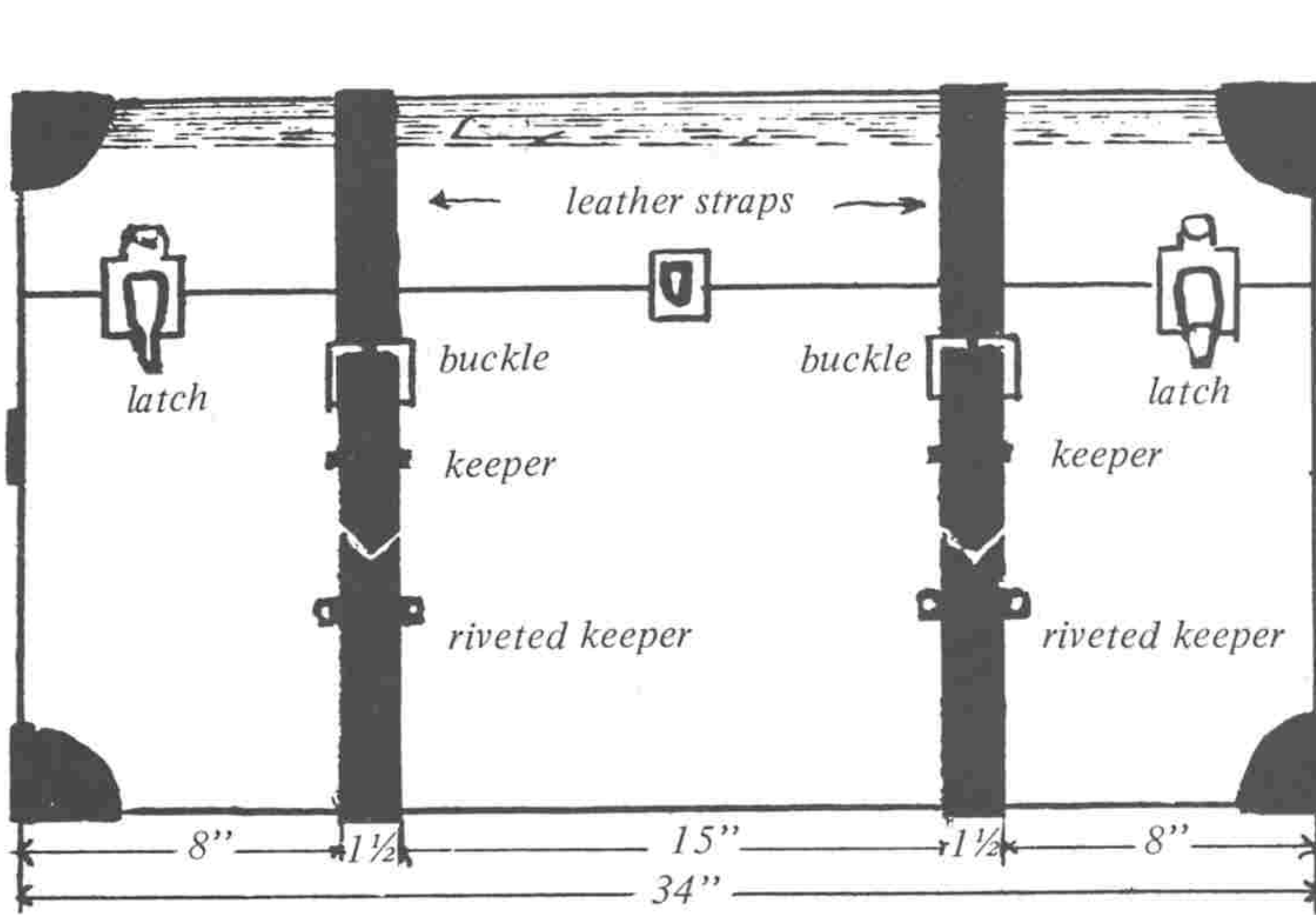

Fig. 1—front of trunk

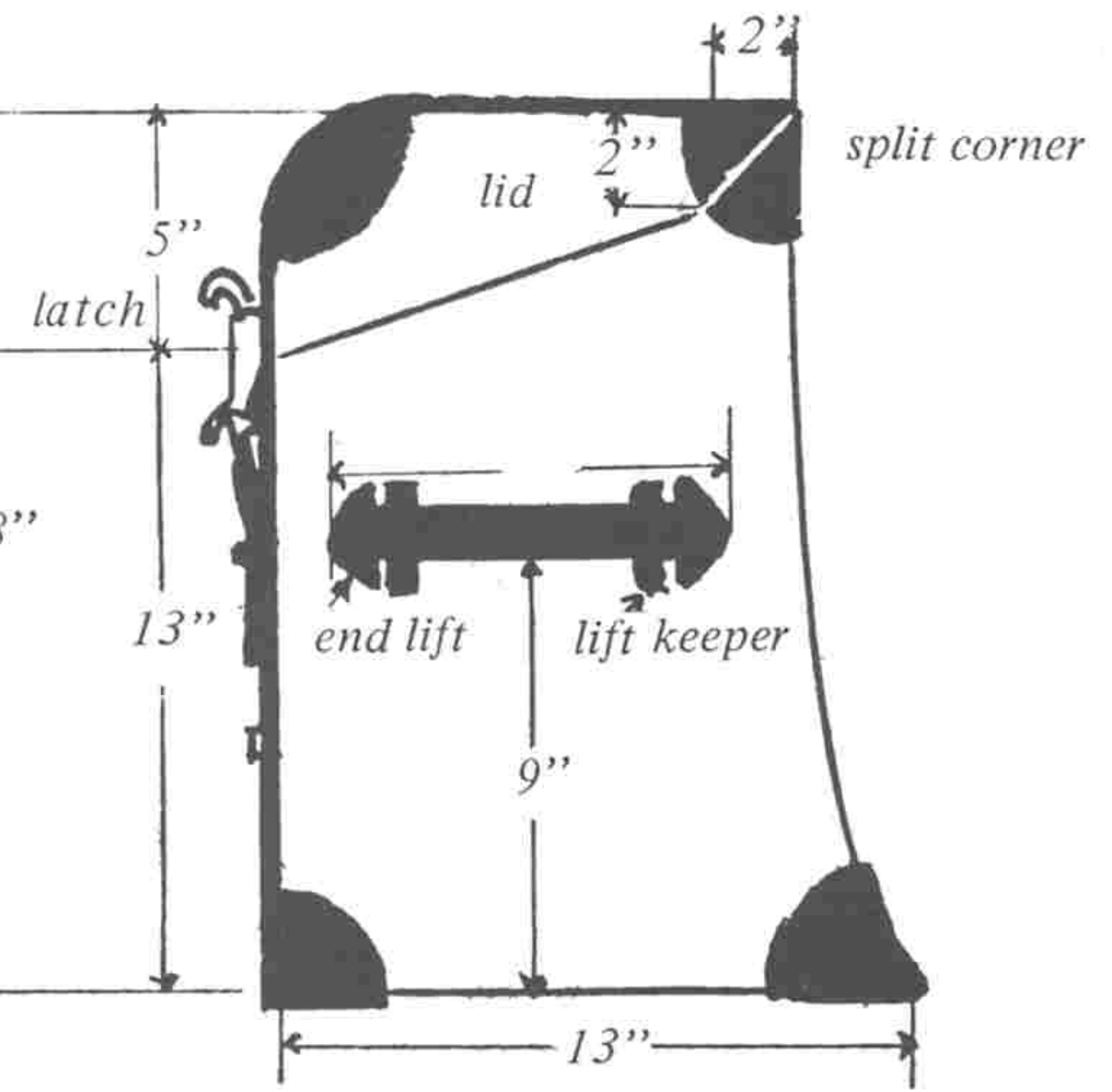

Fig. 2—end view

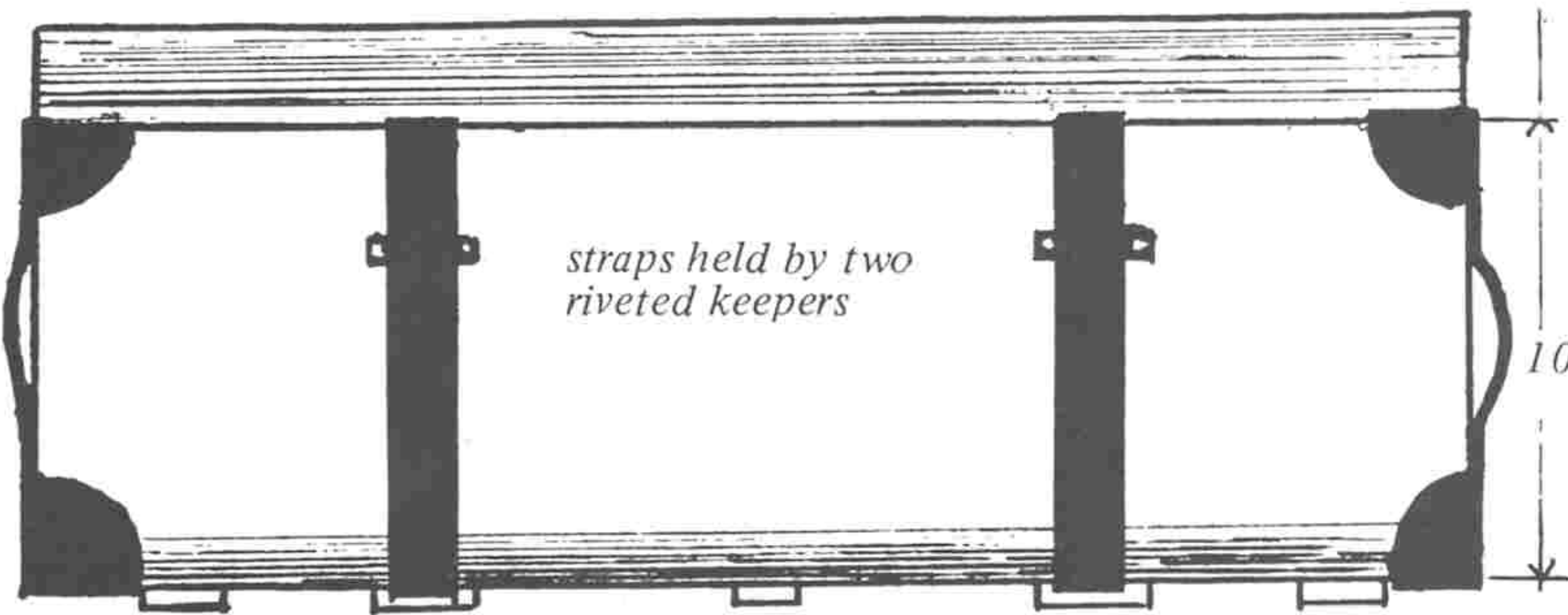

Fig. 3—top view

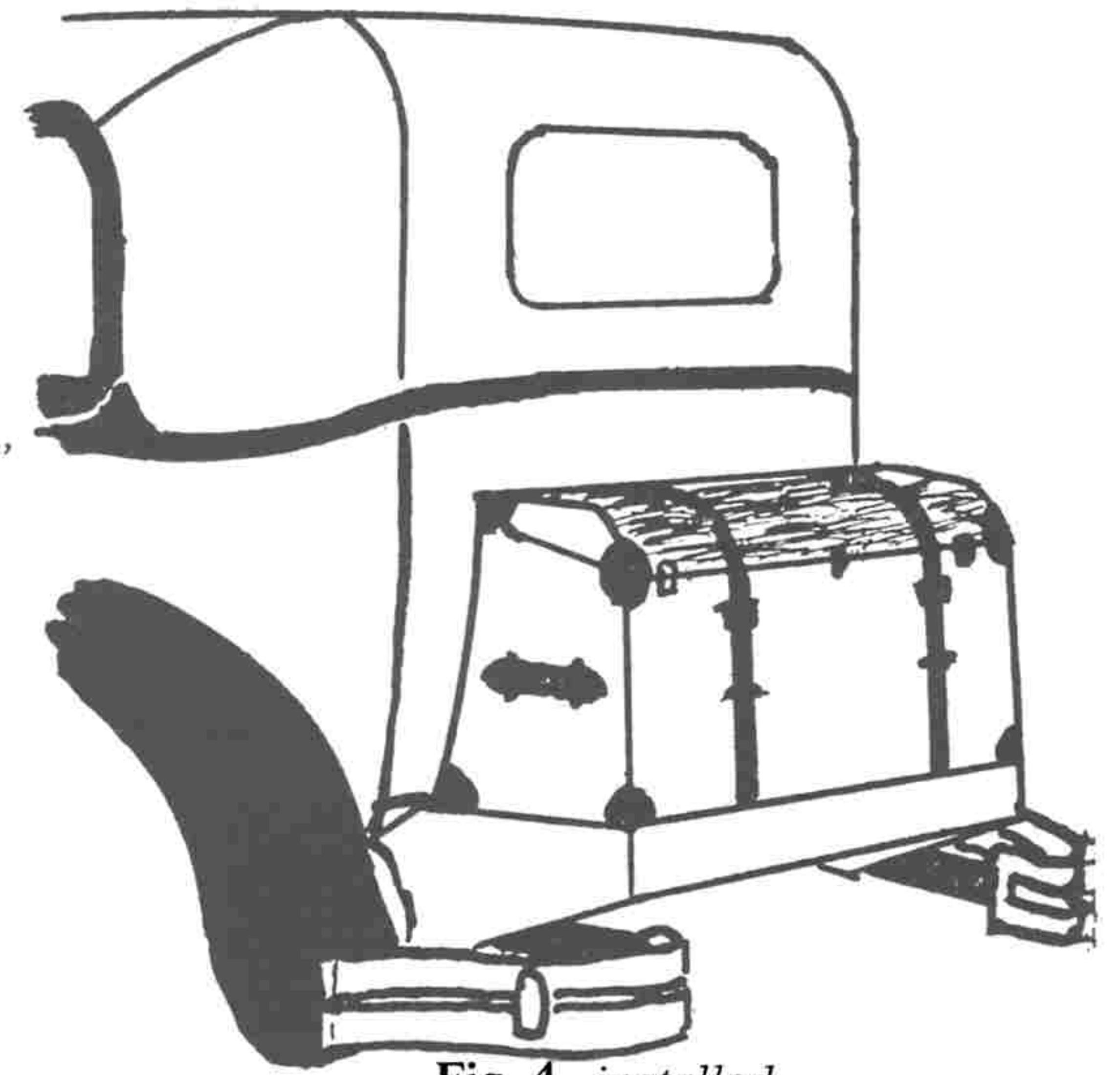

Fig. 4—installed

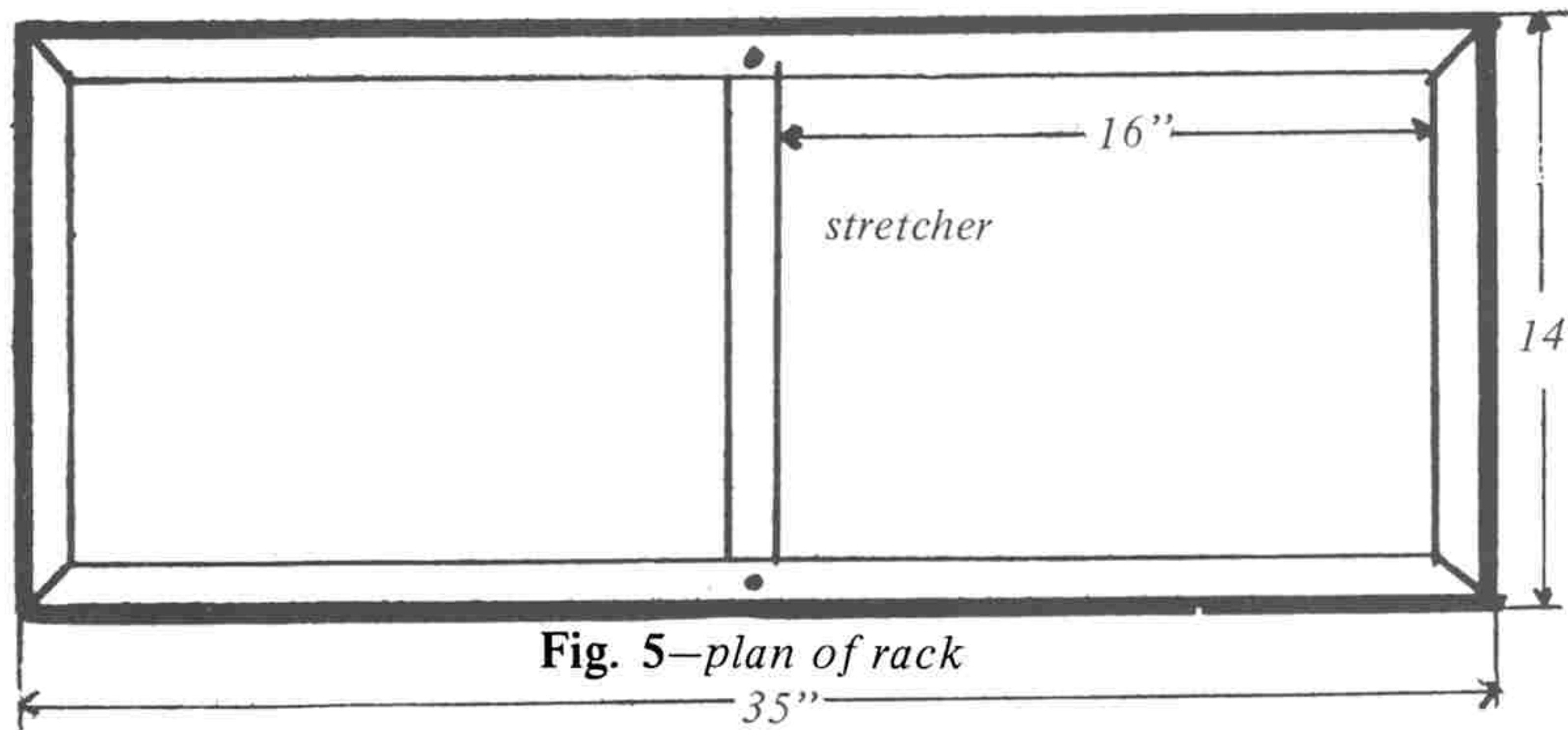

Fig. 5—plan of rack

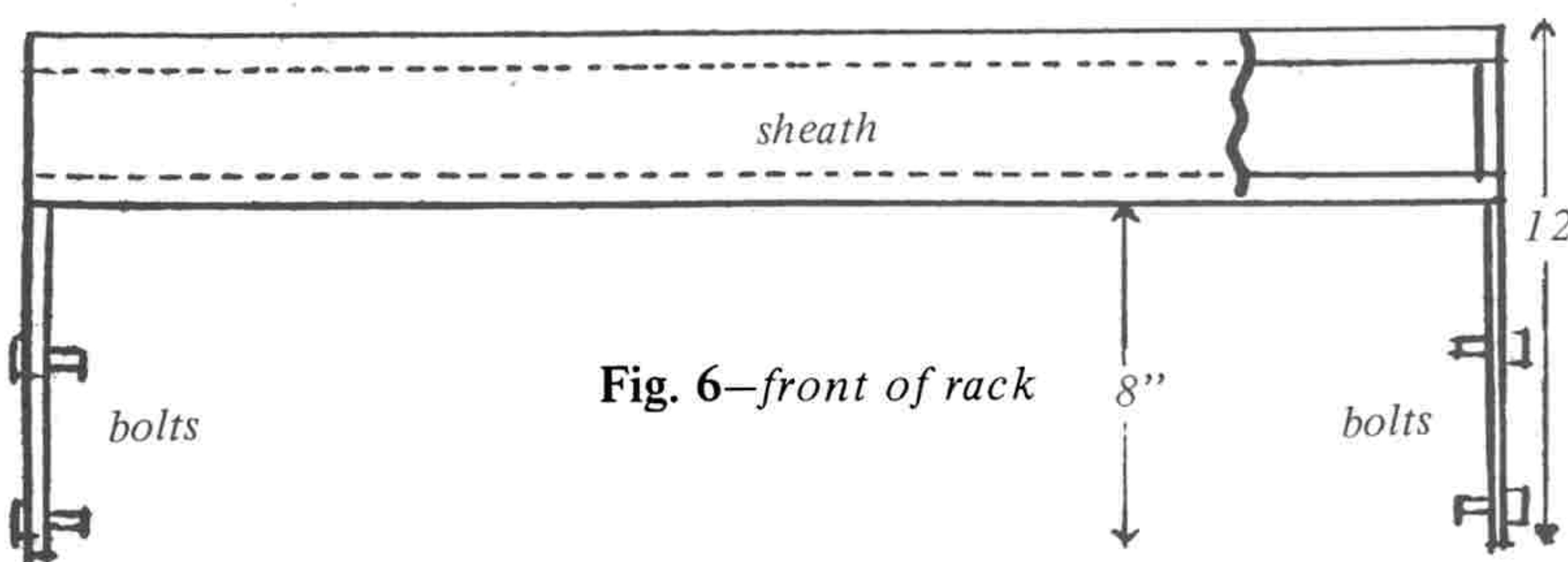

Fig. 6—front of rack

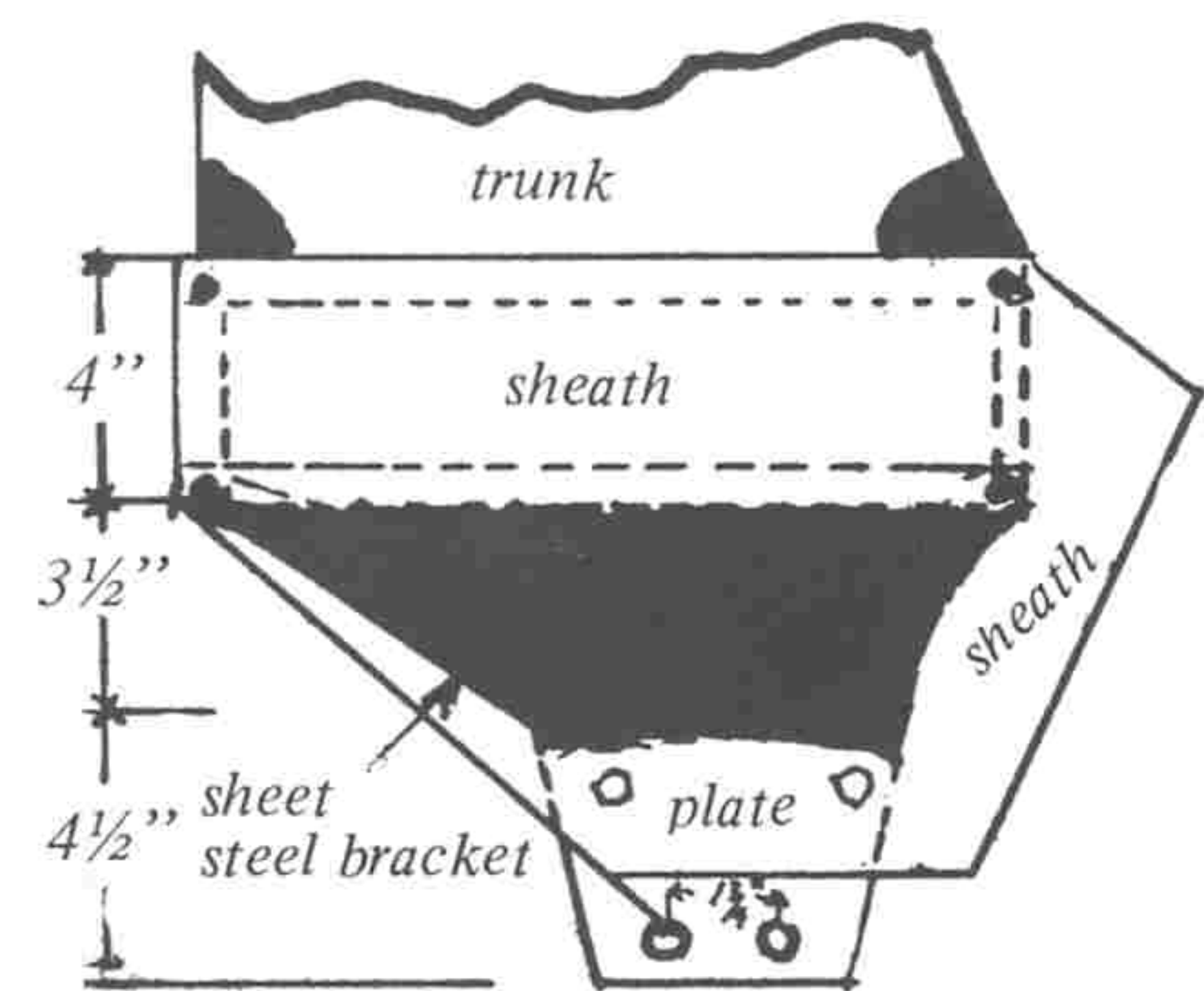

Fig. 7—end of rack

(Opposite) A luggage trunk and rack made especially for the Model A Ford Tudor sedan by the Standard Safety Corporation of Los Angeles.

Drawings from the July, 1929, issue of *The Automobile Trimmer & Painter* magazine—detailing the Model A Tudor Sedan luggage trunk.

(Note: Co-author, Marshall Lewis, scaled down his trunk to 31-inches over-all for a less-bulky appearance).

template must be made from the actual curve of the body panel.

The ends of the trunk are made up from 5/8-inch exterior grade plywood and shaped as in Figure 9. It is very important that the left and right ends be shaped exactly alike. Dimensions are shown in Figure 9 exact to size. First the ends are cut to shape then the lid end is cut out of this so the curve and opening will match (see Figure 11 page 13).

The front panel and the floor of the trunk are made from 1/4-inch exterior plywood. The front panel is glued and nailed to the two end pieces, coming flush with the bottoms of the two end pieces. Figure 12A shows this construction. The floor fits the two end pieces—overlapping, glued and nailed in place.

An oak 5/8 x 2-inch stretcher (see illustration below), set in flush with the rear side of the end pieces, holds them in alignment and provides a secure anchorage for the lid hinges. See Figure 13. A sheet of 1/4-inch exterior plywood will be used to close the back side of the trunk, and it will be nailed to the floor, the ends, and to the stretcher at the top. But this is not installed until after the stretcher has been lined (this is important since the workman can line the trunk far more easily with the back off).

The lid is built in a manner similar to that used in building the trunk. That is (see Figure 14), the two ends are held together by a panel of 1/8-inch plywood at the front, a 5/8 x 2-inch oak stretcher at the top rear. (Note: MacClary called for a lid covered with bent sheet iron. Lewis found that soaking a piece of 1/8-inch exterior plywood in water and bending it to fit made a tidier job).

—continued on page 14—



An oak "stretcher" is an important part of the well-built luggage trunk. It gives strength to the structure and serves as an excellent hinge mount. Lewis cut end shape from plywood then cut out lid "closer" from that. Both ends must match perfectly.

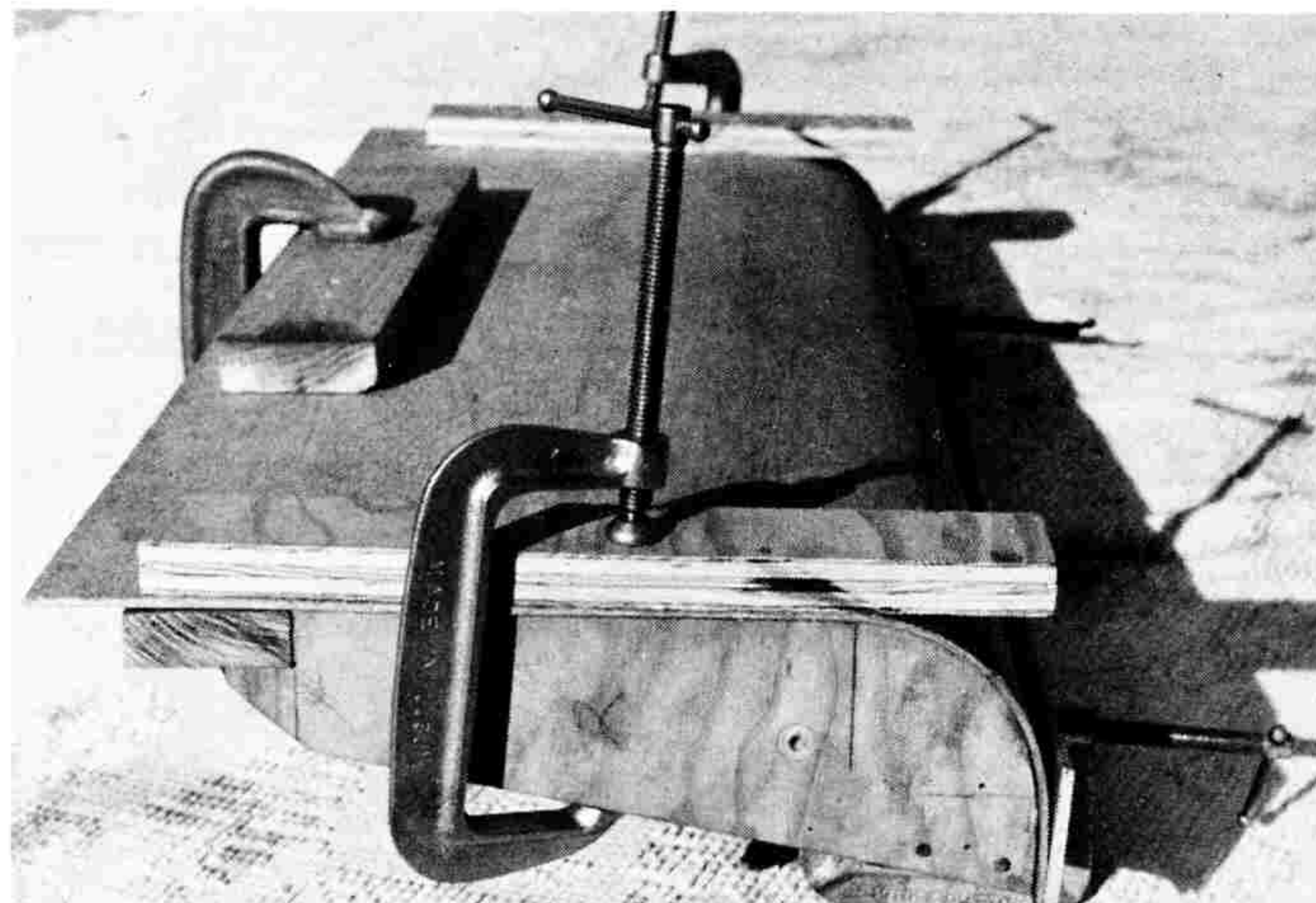

Lid also utilizes oak "stretcher" to mount piano hinge. Professional look is obtained by forming curved top from wet 1/8-inch exterior plywood which has been clamped, glued, tacked and screwed.

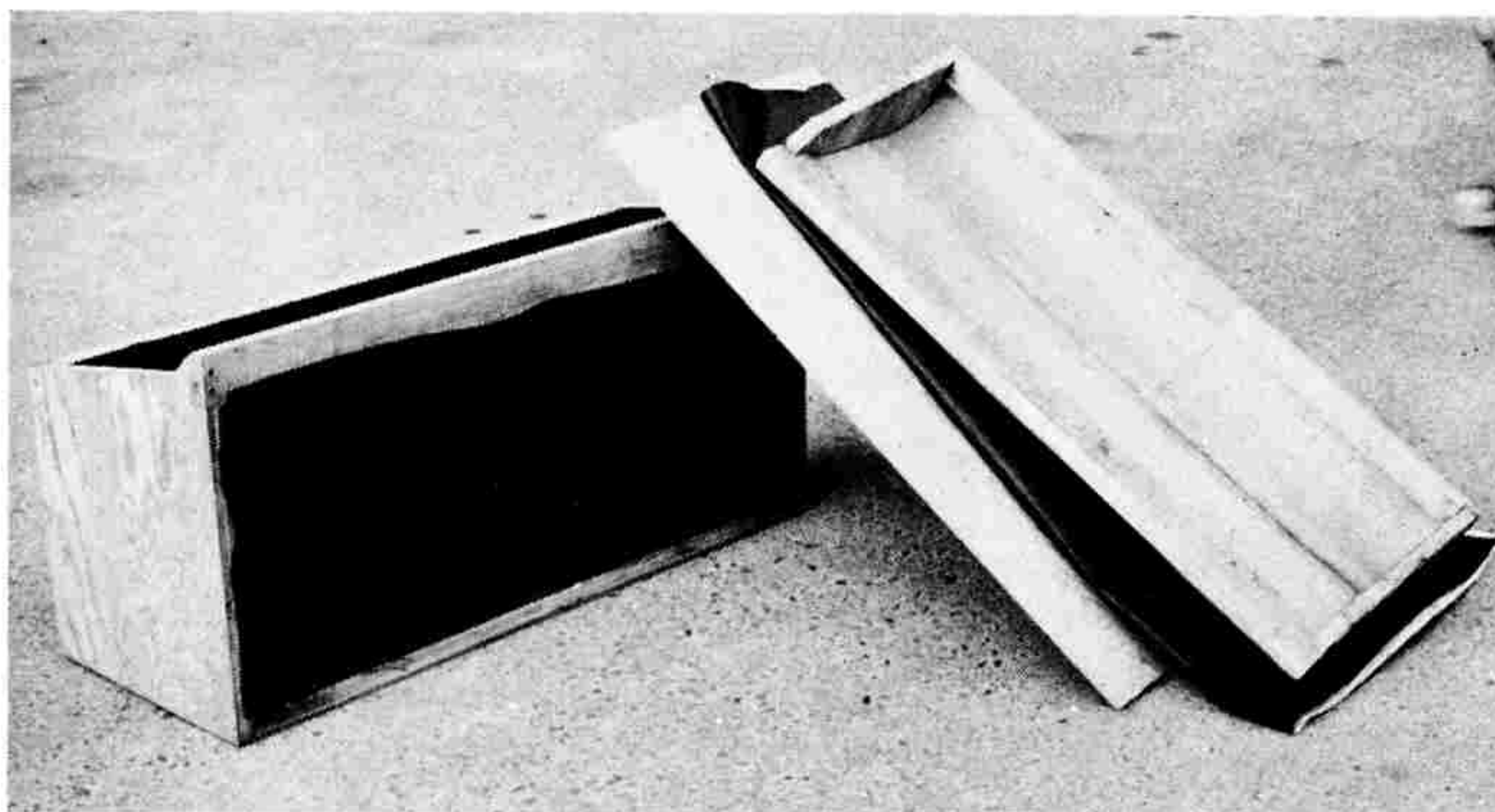

Inside of trunk is lined first before the back and lid is lined and attached. This is important for a smooth job!

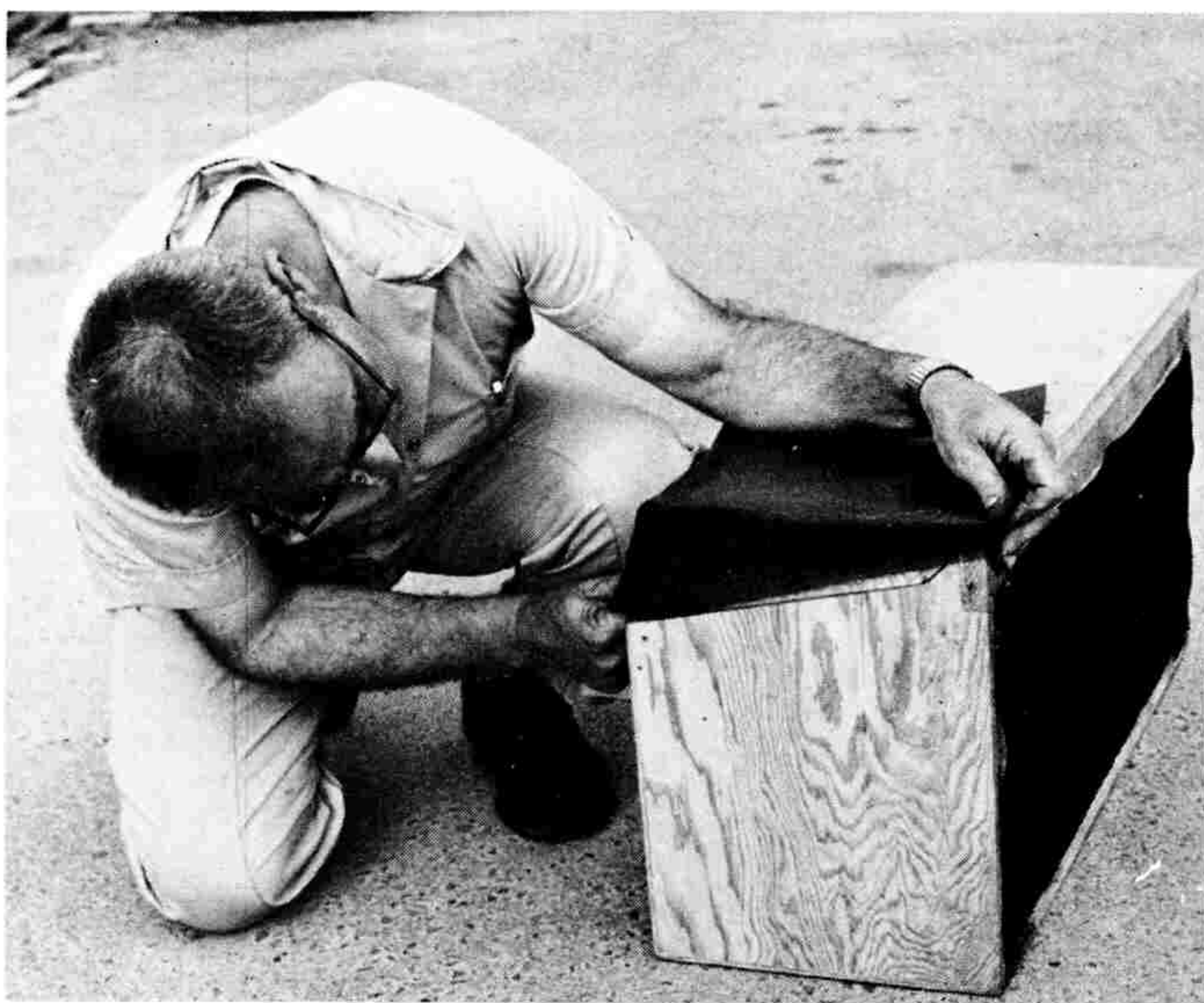

Marshall Lewis, as he checks the fit of his material to the trunk lid. At this point the lid and inside of trunk have been lined but the back has not yet been attached.

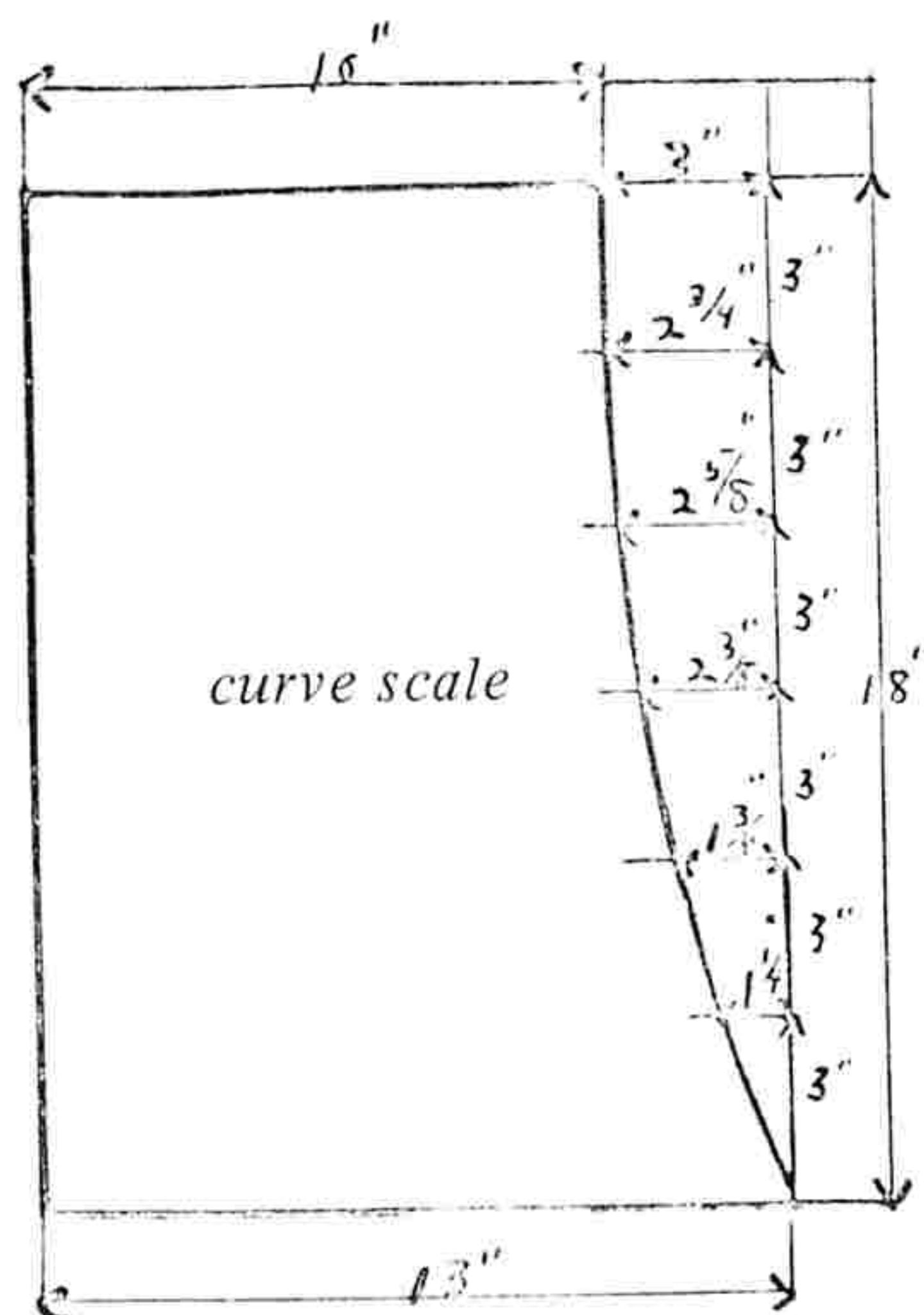

Fig. 8

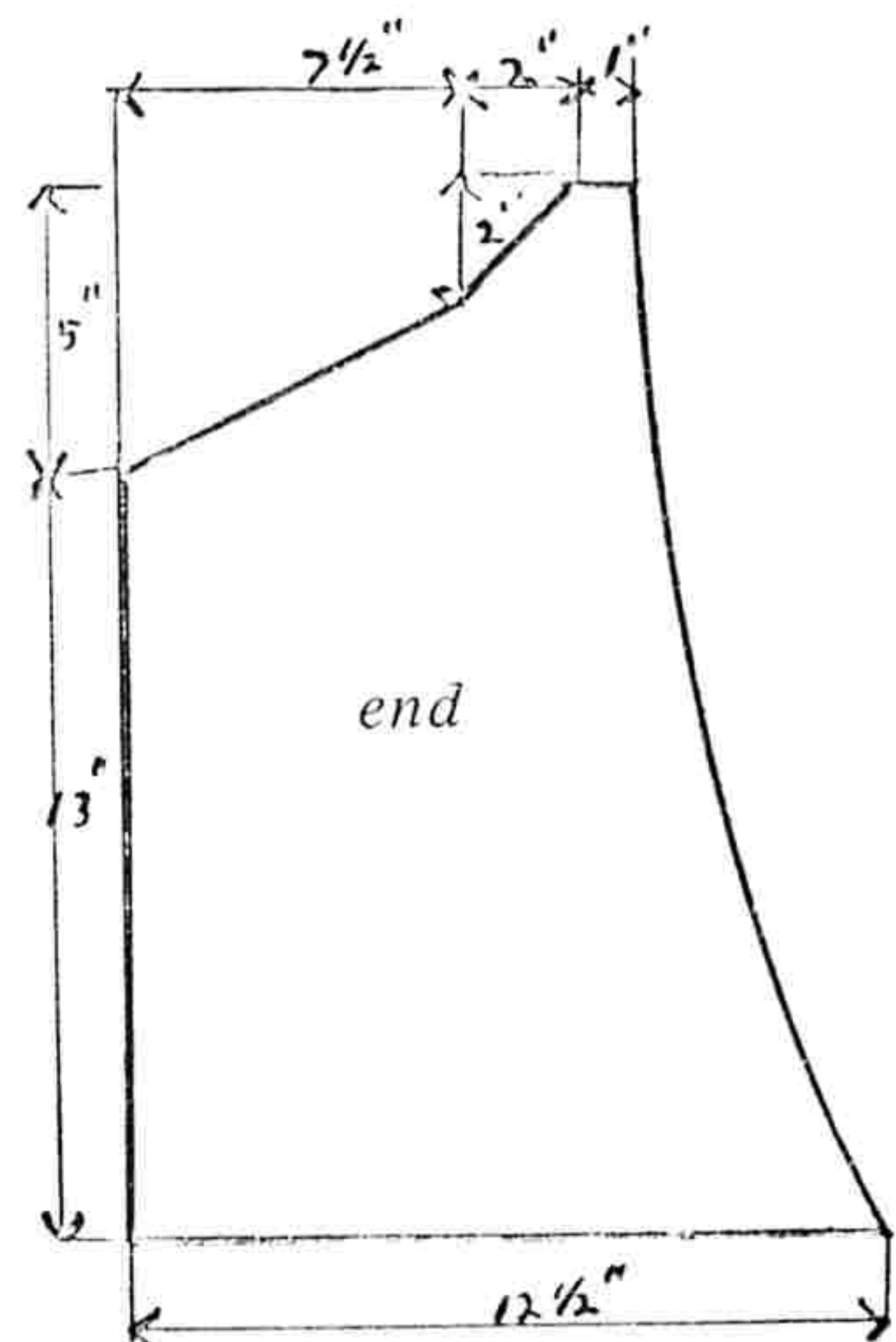

Fig. 9

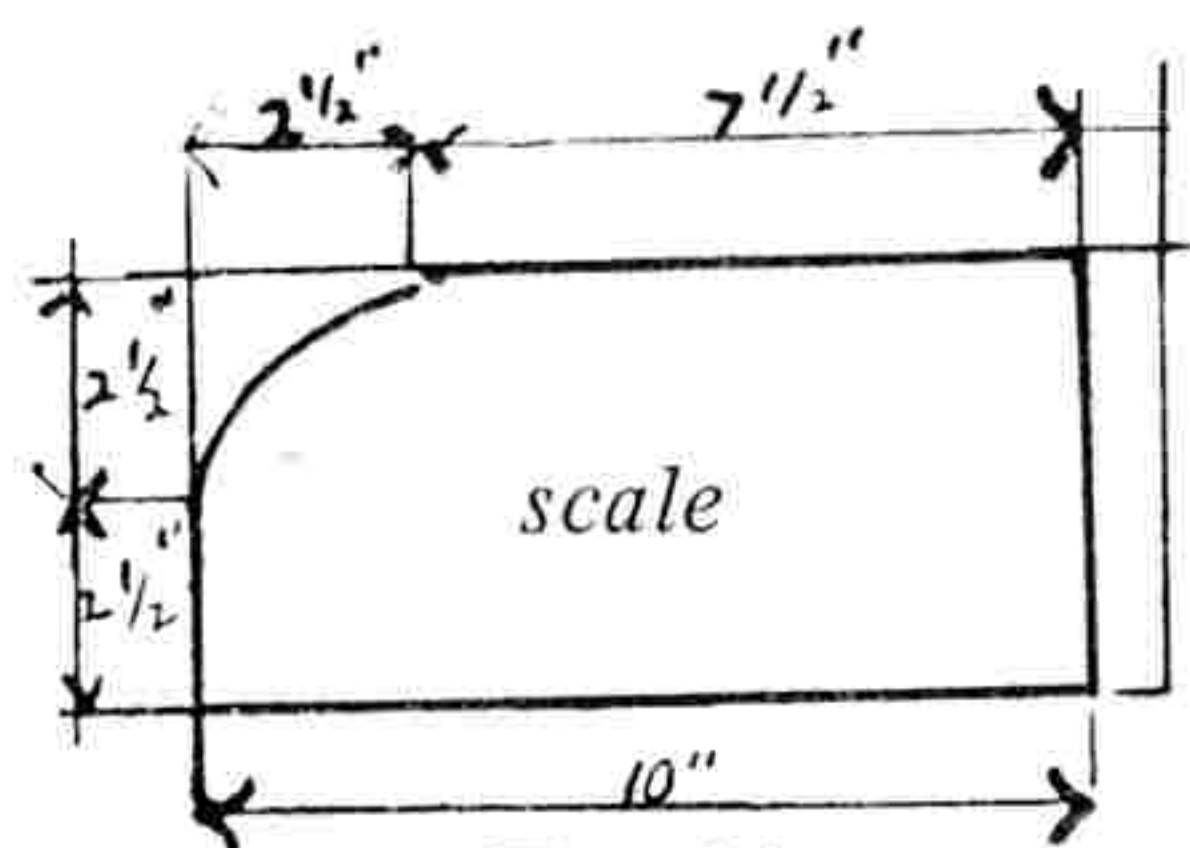

Fig. 10

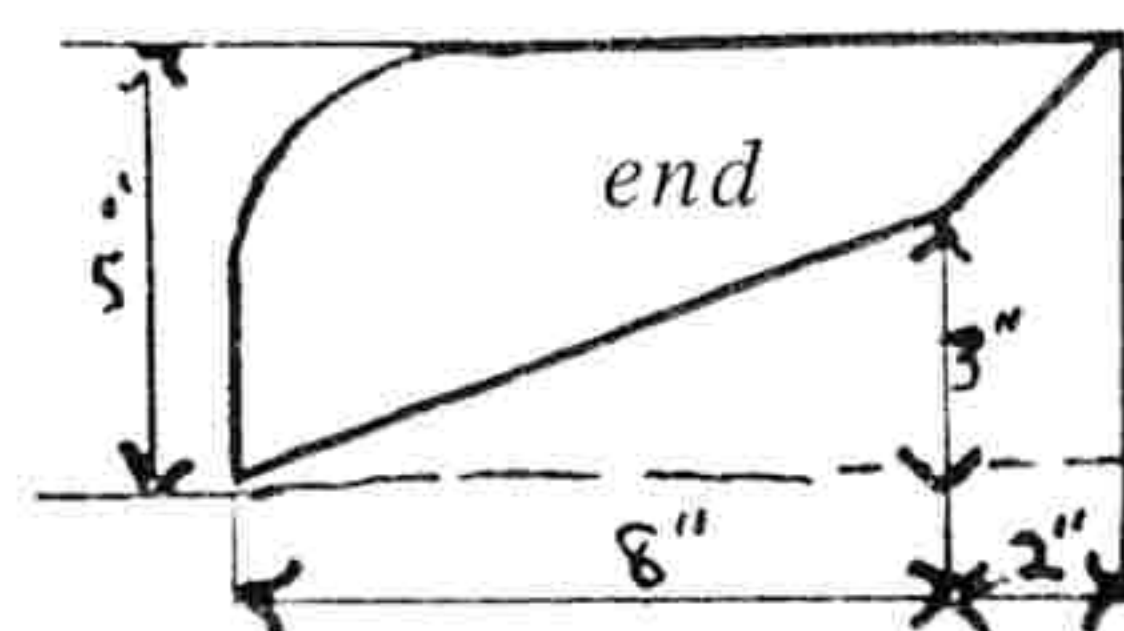

Fig. 11

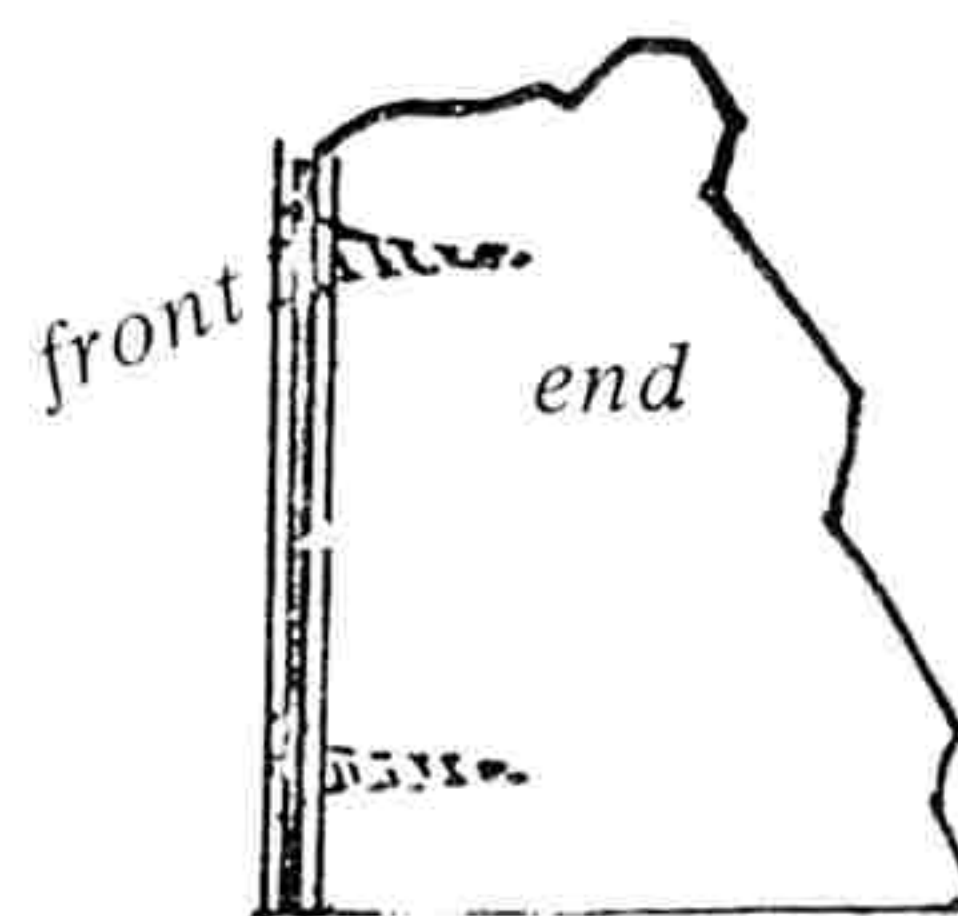

Fig. 12A

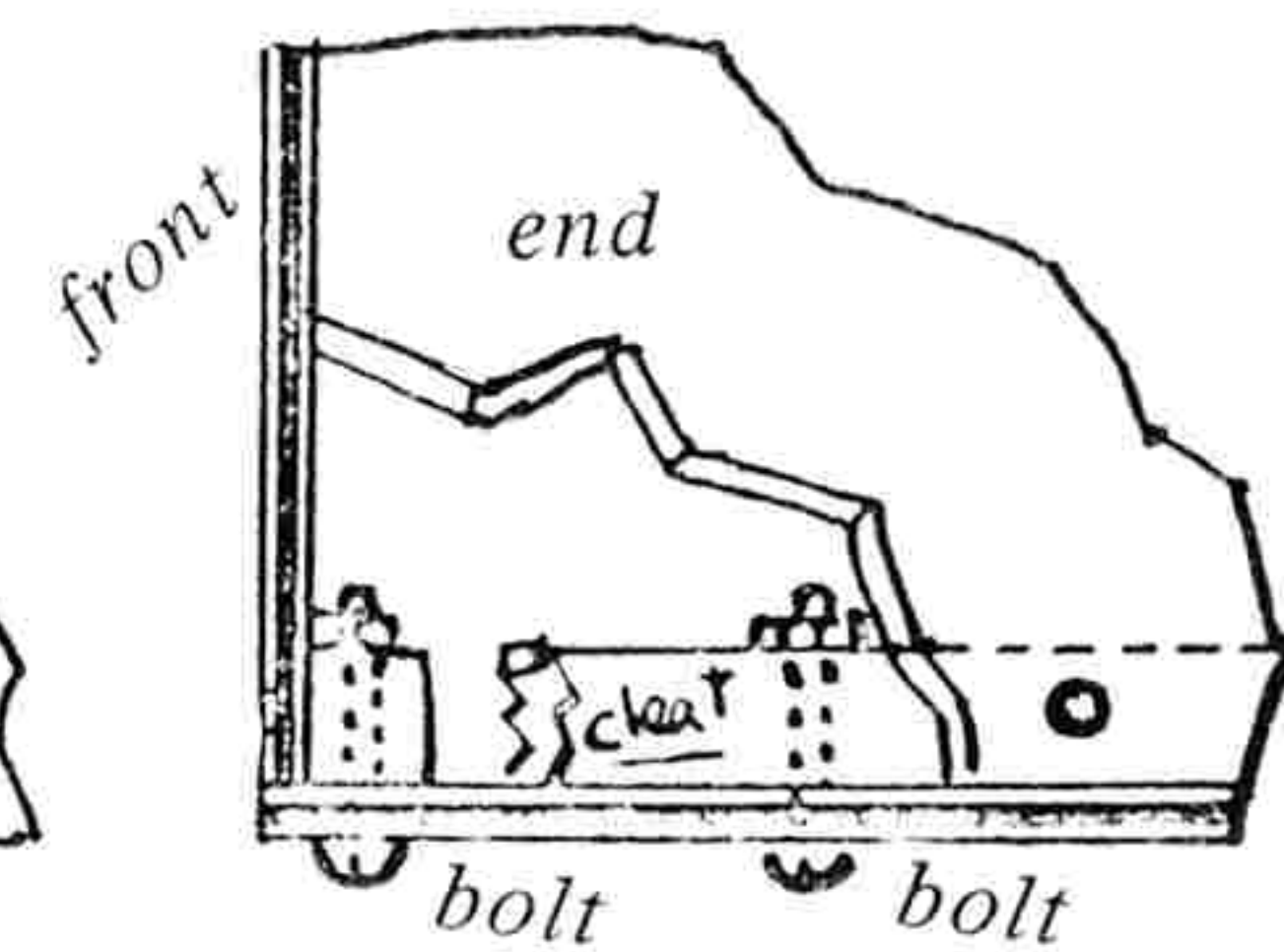

Fig. 12B

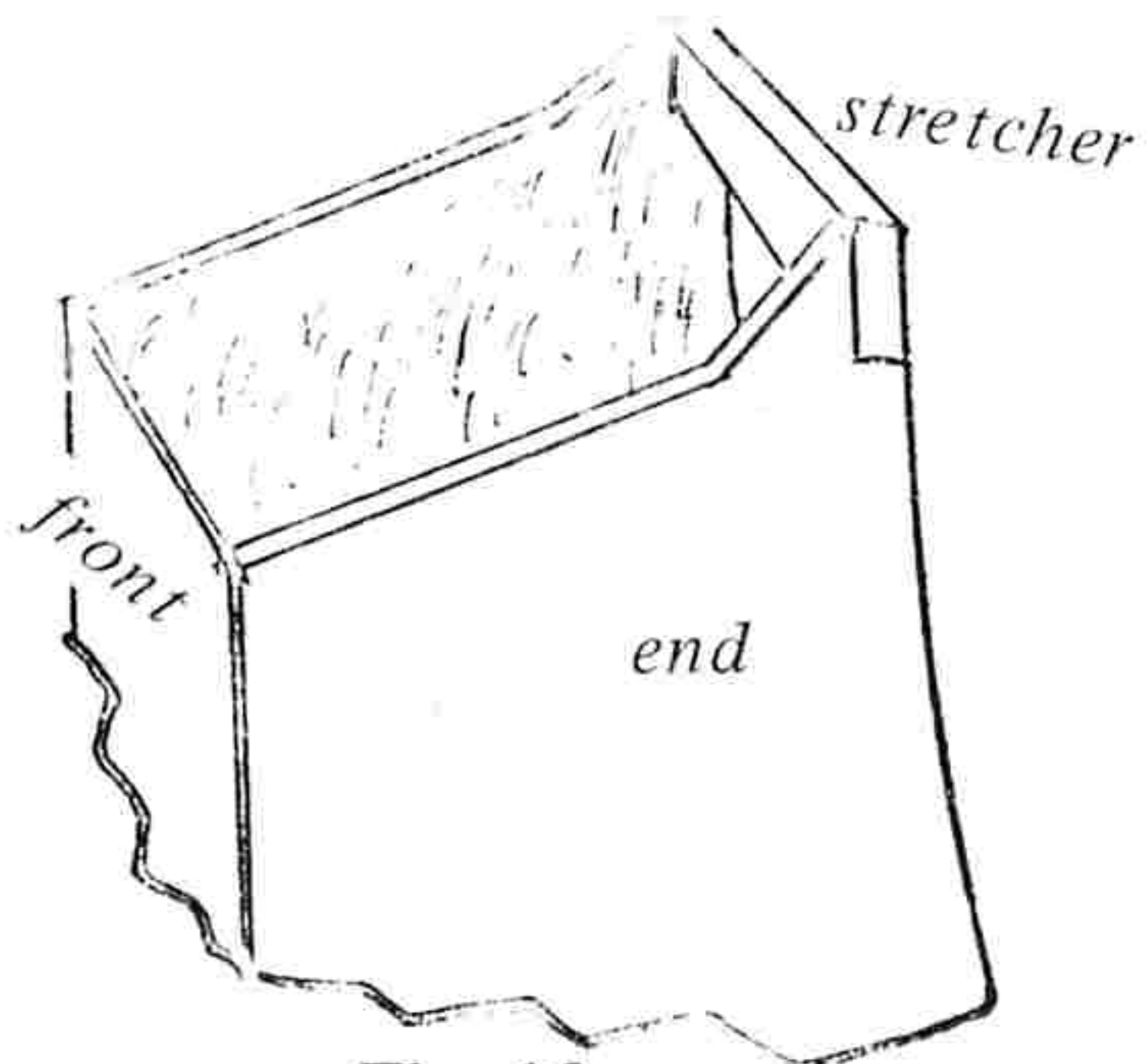

Fig. 13

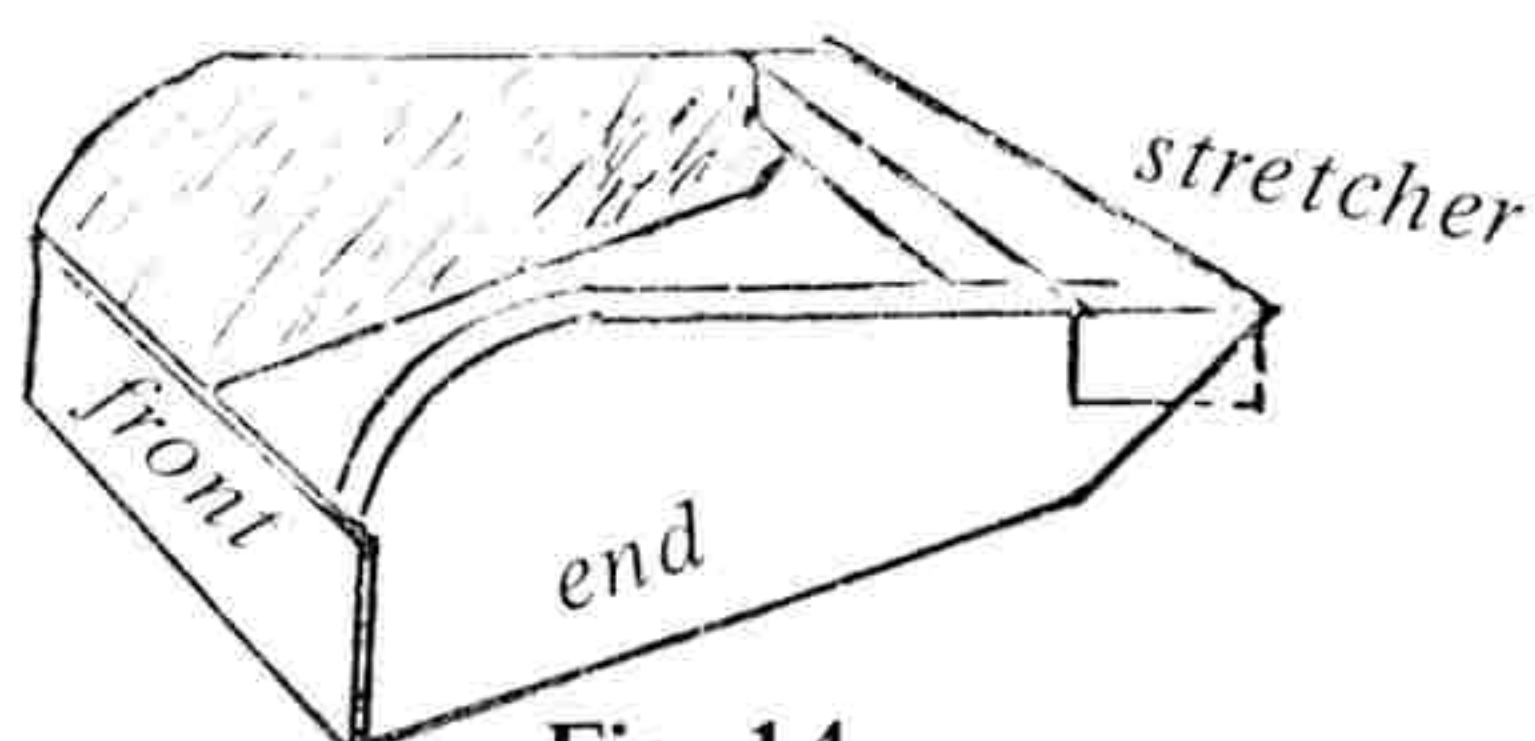

Fig. 14

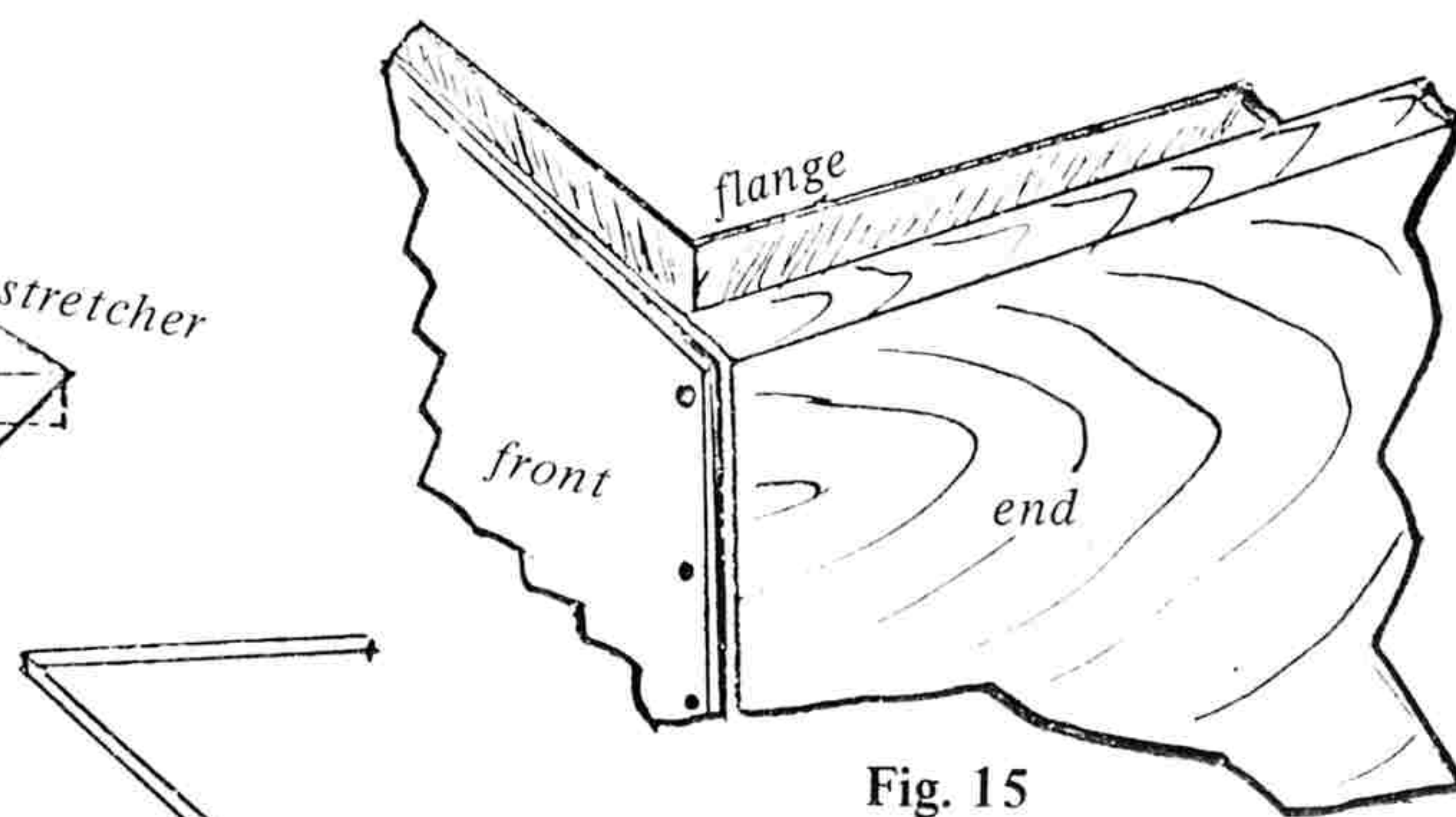

Fig. 15

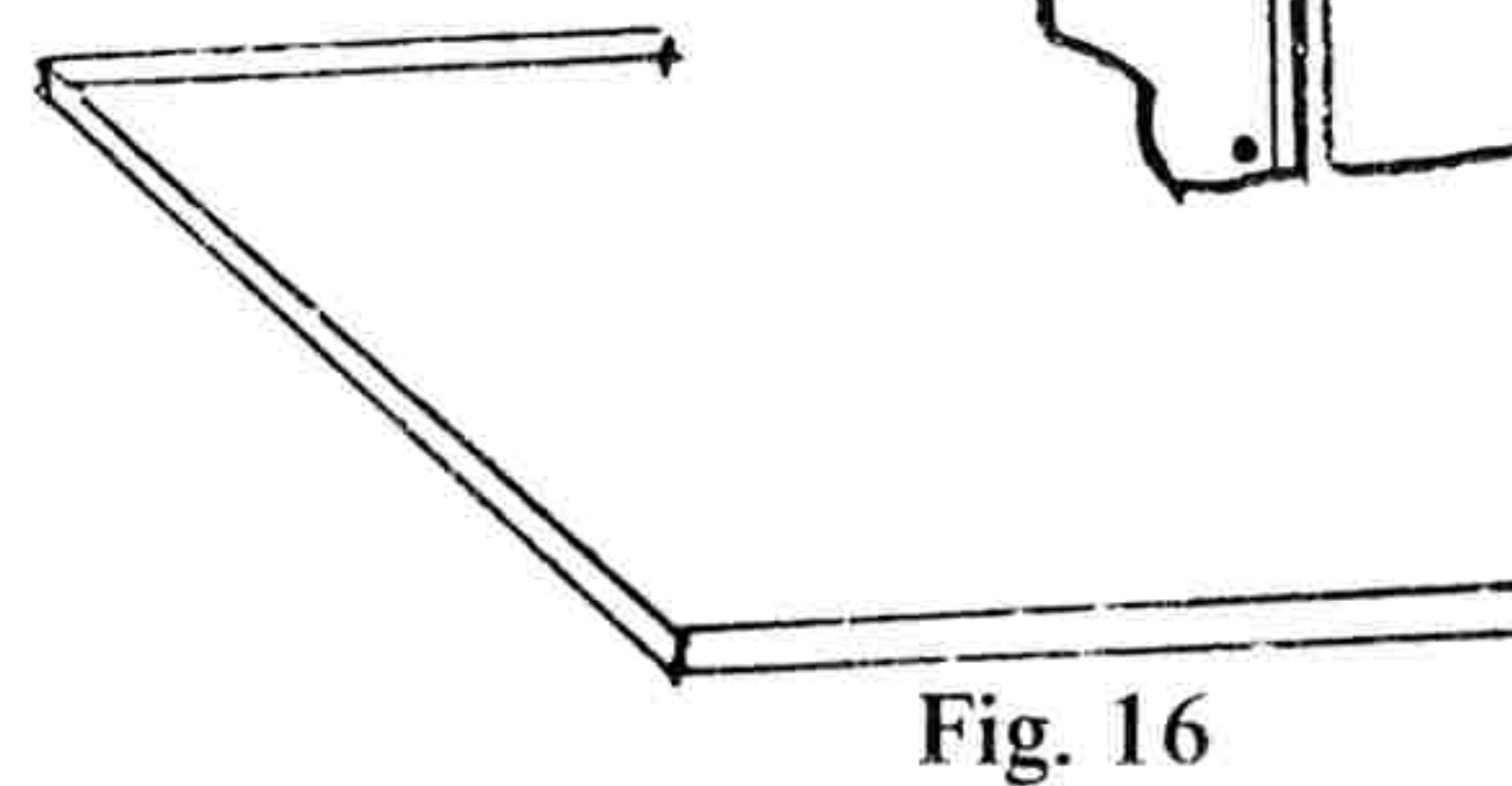

Fig. 16

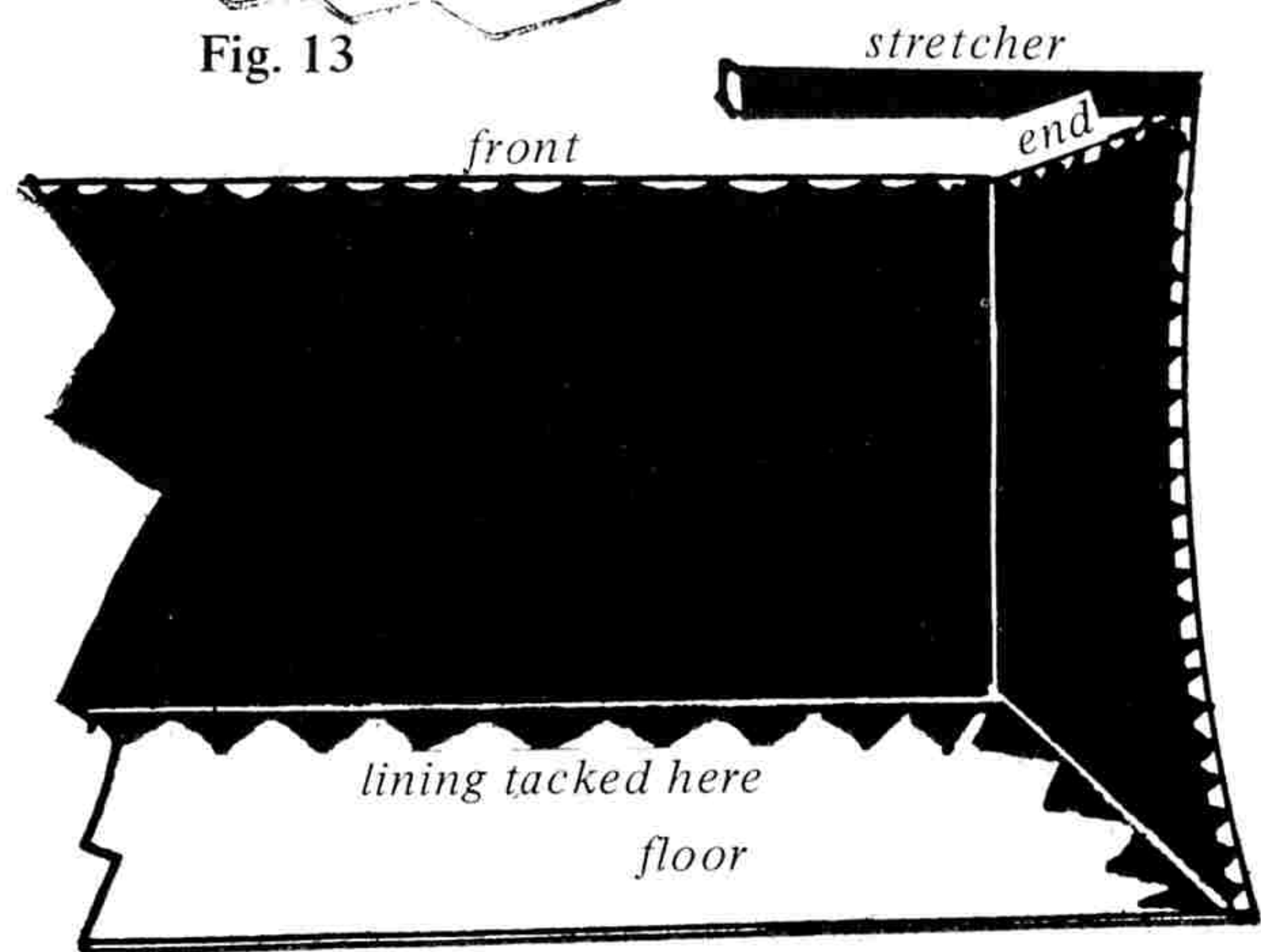

Fig. 17

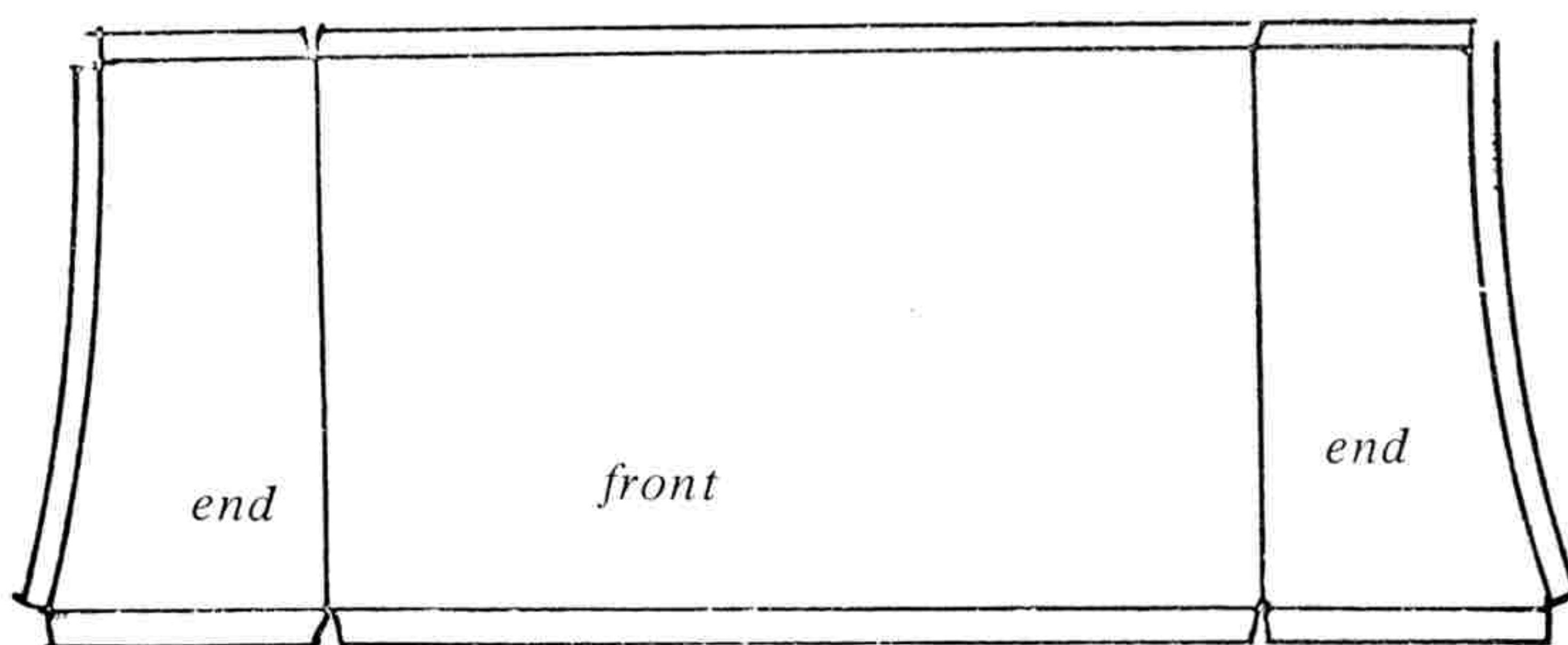

Fig. 18

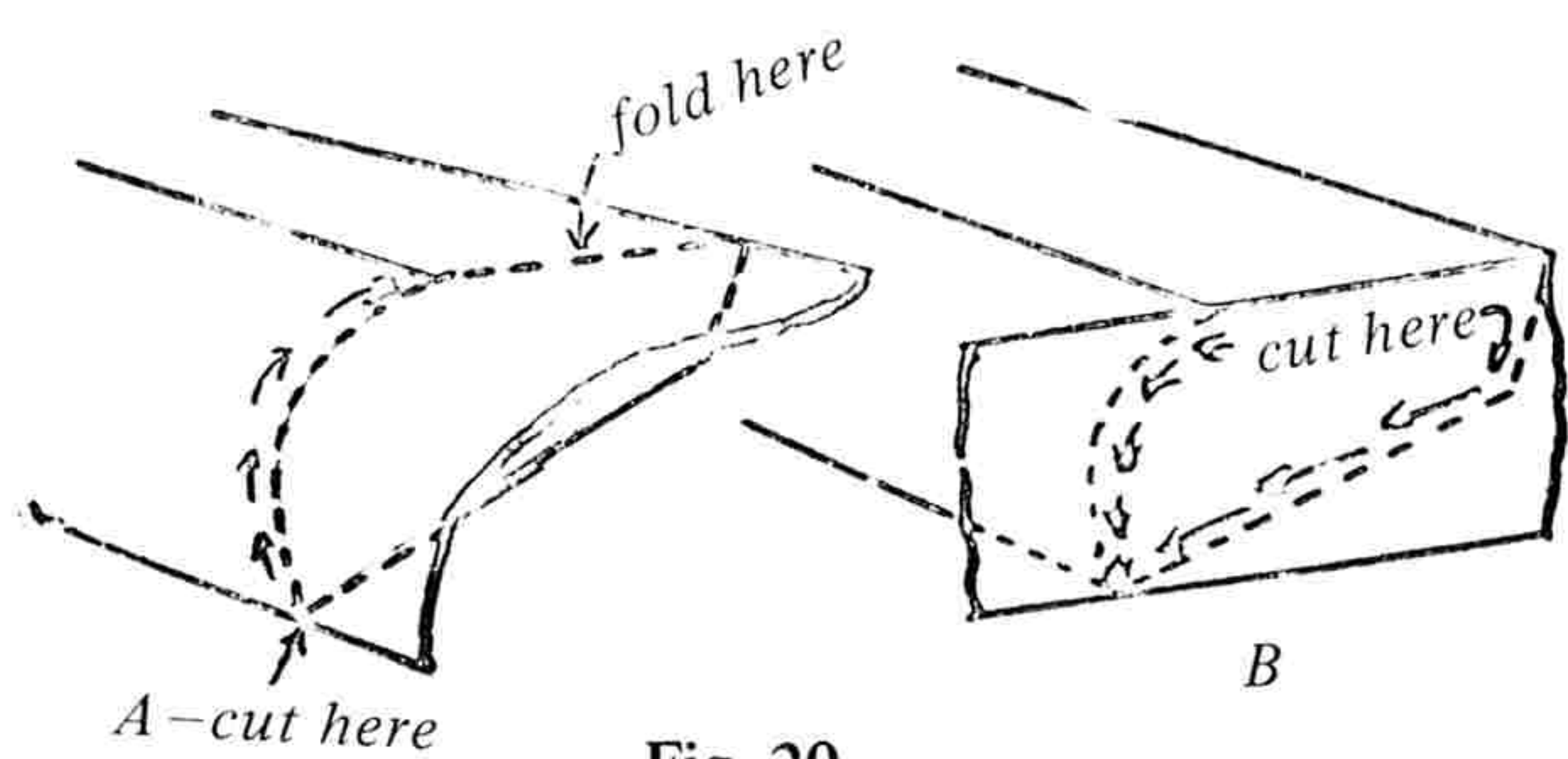

Fig. 20

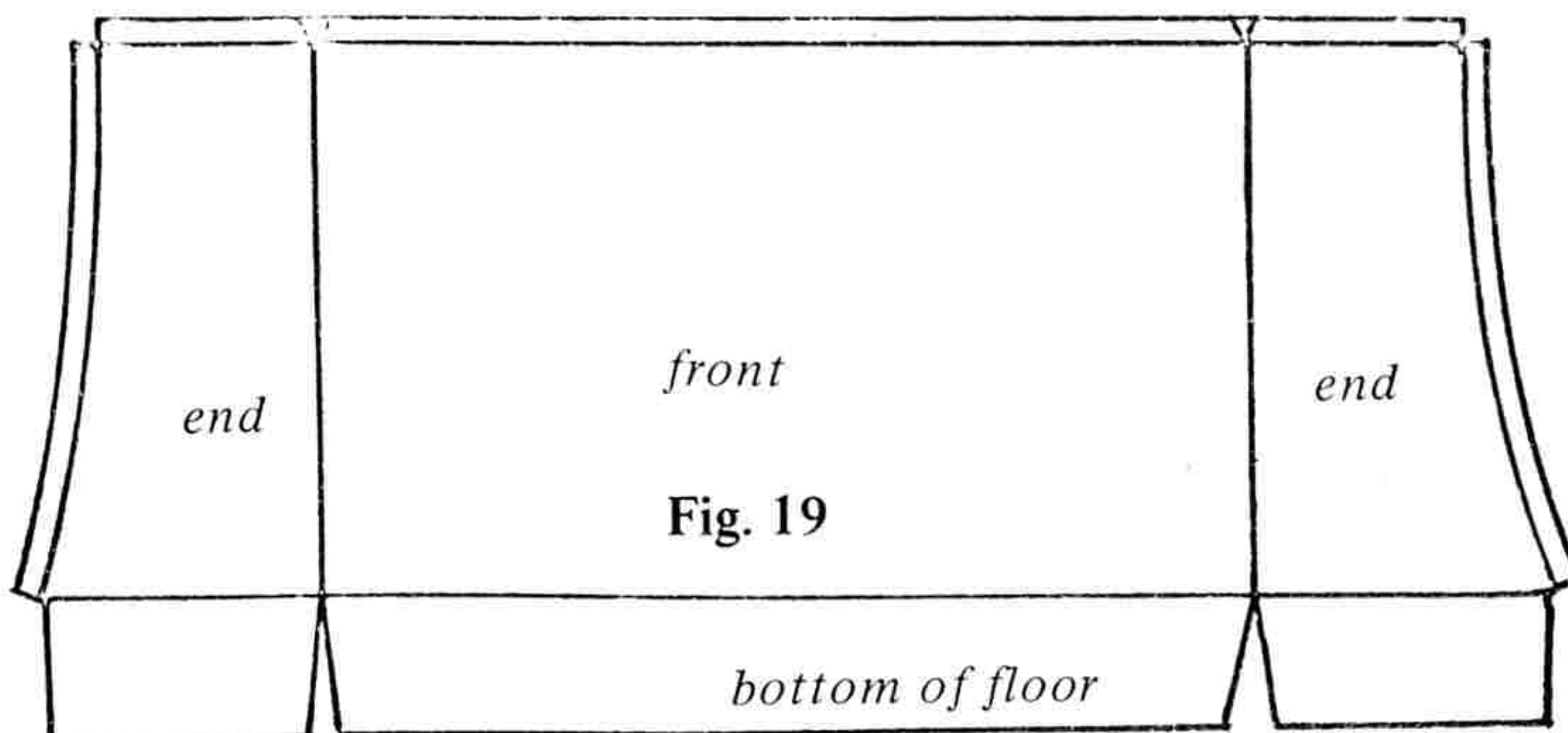
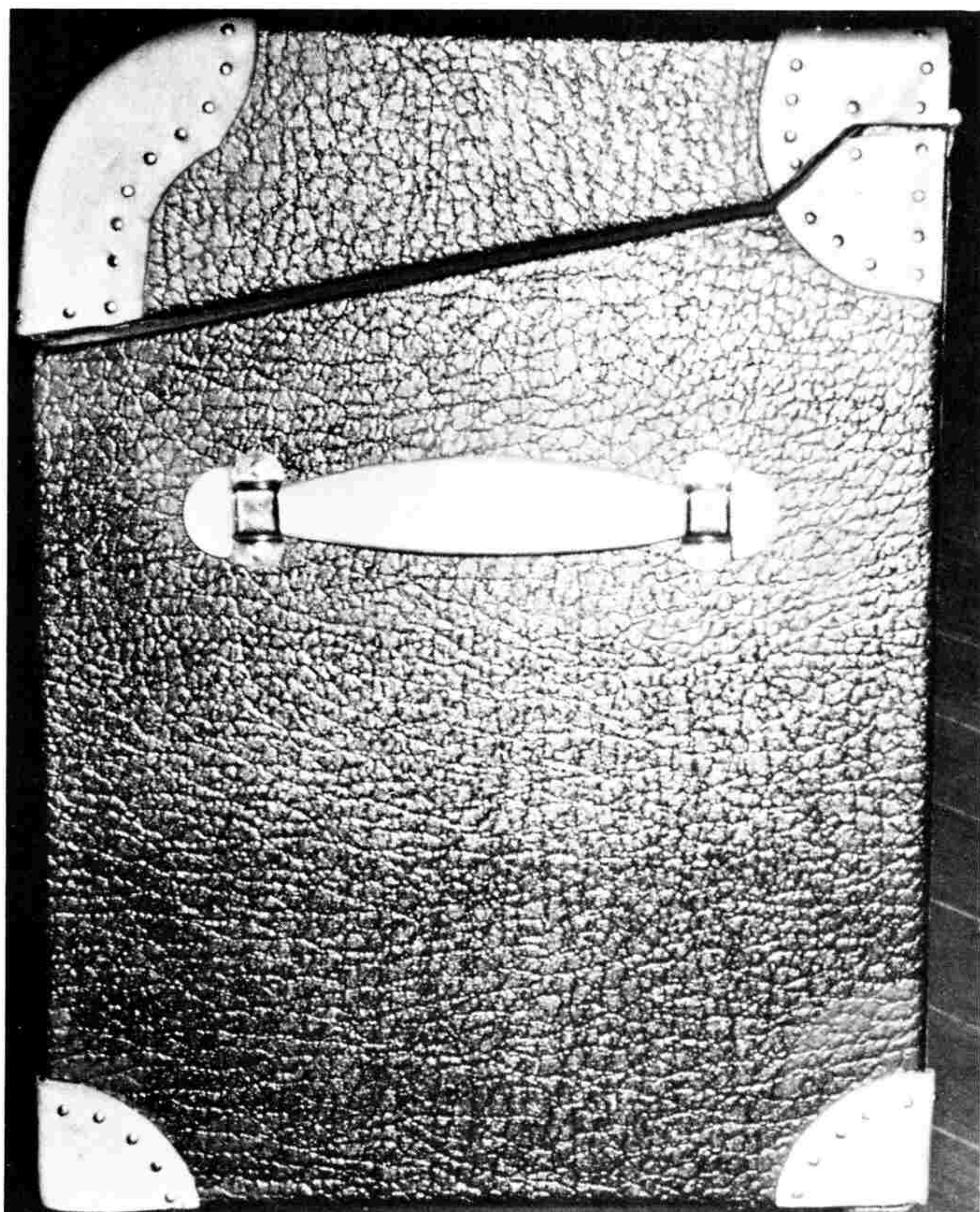

Fig. 19



Finished end of luggage trunk built by Marshall Lewis showing leather corners and end-lift details.

In order to prevent dust from entering the trunk through the joint between trunk and lid, a flange or lip must be provided as in Figure 15. This flange is made of 20-gauge sheet metal (Lewis used stainless) cut to fit all around then drilled and secured with countersunk flat-head wood screws. Next, common foam weatherstripping material is glued to the underside of the lid lip to make a dust-proof seal when the toggle latches are snugged up and locked.

Lining the Trunk

The trunk and lid have now reached a stage where they may be lined. For this purpose a light-weight naugahyde-type material is recommended (black is standard color). It should have a smooth, glazed finish to permit easy cleaning with a cloth. A soft-textured lining material will catch dust and resist cleaning. This material need not be of an expensive quality as it is not subjected to the elements or to road wear.

Coat the inner surface of the front panels with Contact Spray Glue. Cover these three parts with a single piece of lining material, drawing the edges at either end around onto the curved side of the end sections of the trunk. Trim off the edges at the top of the front panel and the end sections. Allow the lower edges to overlap on the floor of the trunk. See Figure 17 for illustrations of the placing of this lining. The floor stretchers are then covered with a single piece of material glued in place. The floor is covered with a piece of lining material glued to lightweight upholstery panel board then dropped into place. Another piece of lining material is glued to the inner side of the plywood which is to enclose the back of the trunk. This may be left with raw edges, as these edges will be concealed when the wood is fastened in place on the trunk. Cover the stretcher at the top back of the trunk with a single narrow strip of lining material. In applying lining material be especially careful to avoid unsightly wrinkles.

In like manner cover the inside of the trunk lid. Coat

the wood surface and the stretcher with Contact Spray Glue. Use a single strip of lining material to cover the lid, two smaller pieces to cover the ends.

Covering the Trunk

A wide variety of vinyl upholstery materials for covering the trunk are available from your local upholstery shop or its supplier. The usual covering is a brilliantly glazed long grain or pebble grain black material. (Note: MacClary's article went on to point out that custom trunks often were matched to the material used on the Model A top decking or canvas top).

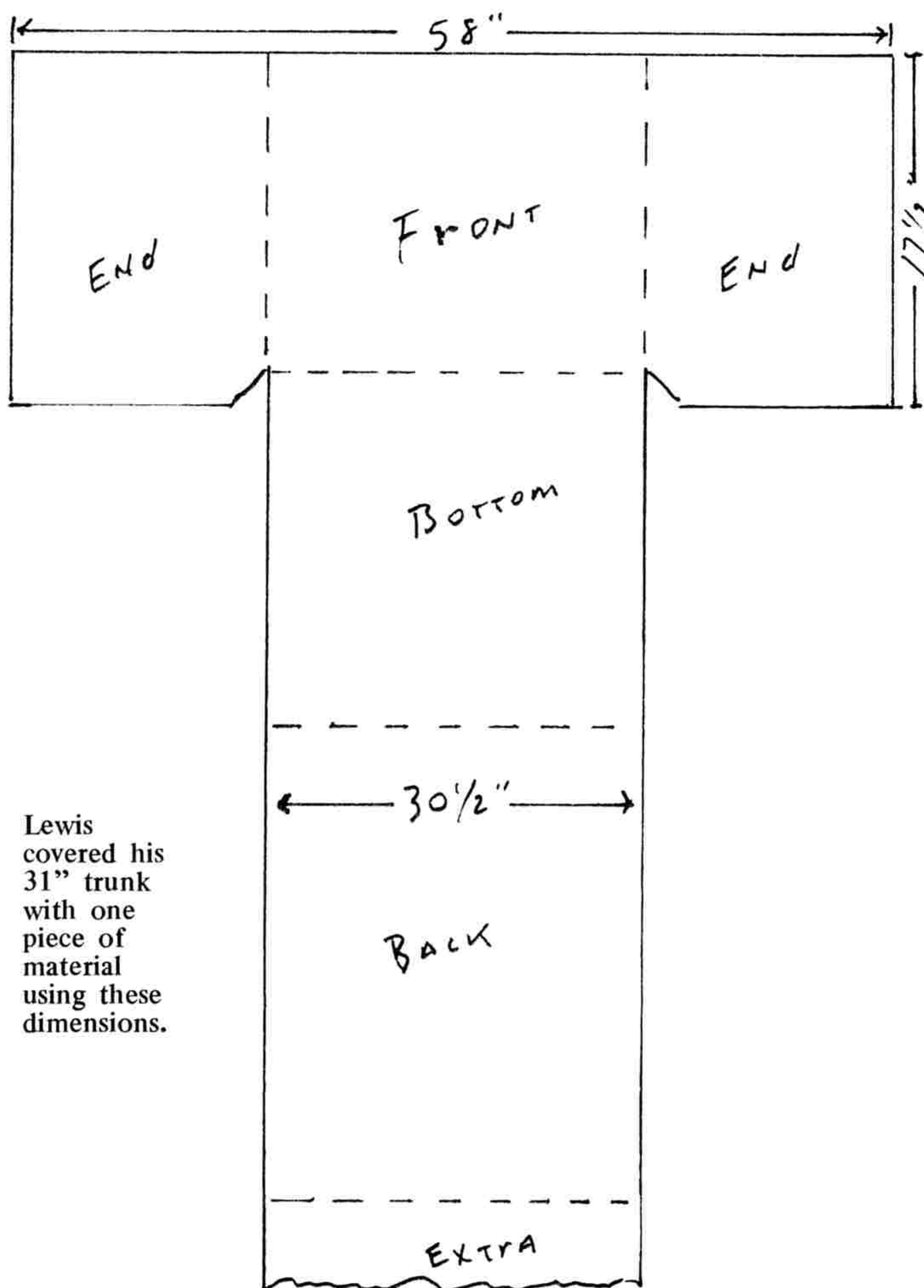

Lewis covered his 31" trunk with one piece of material using these dimensions.

A single piece of covering material stretches around the two ends and the front panel of the trunk, being held in place by a coating of Contact Spray Glue, and secured in back of the trunk by tacks driven into the rear side of the end sections. It is customary to attach the back sheet of plywood before this is done. Sometimes a single piece of covering material is used for front, ends and bottom. This is costly, particularly if the covering material is high priced but will give a better appearing job.

The upper edge of the covering material is brought up and over the top edge of the front panel and end pieces and is there secured by tacks and glue. This raw edge will be finished off by the metal flange or lip discussed earlier in the article. The back of the trunk is also covered with material. This covering is tacked to the bottom of the floor, to the rear edge of the end pieces and to the reinforcing stretcher at the top rear. The two ends are then covered with welt or gimp, concealing the rows of tacks. The bottom and the top edge are concealed without the addition of gimp. Likewise, the

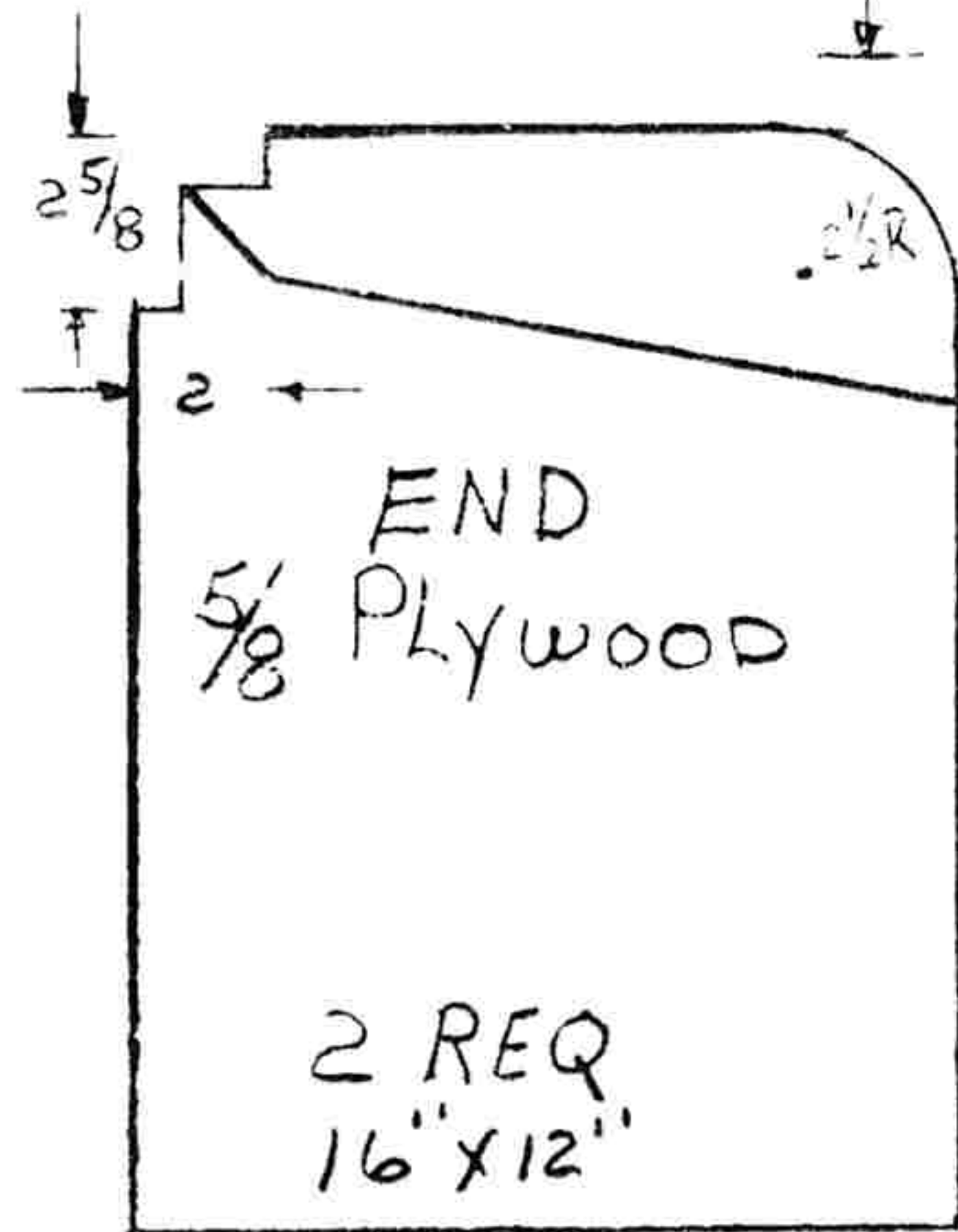
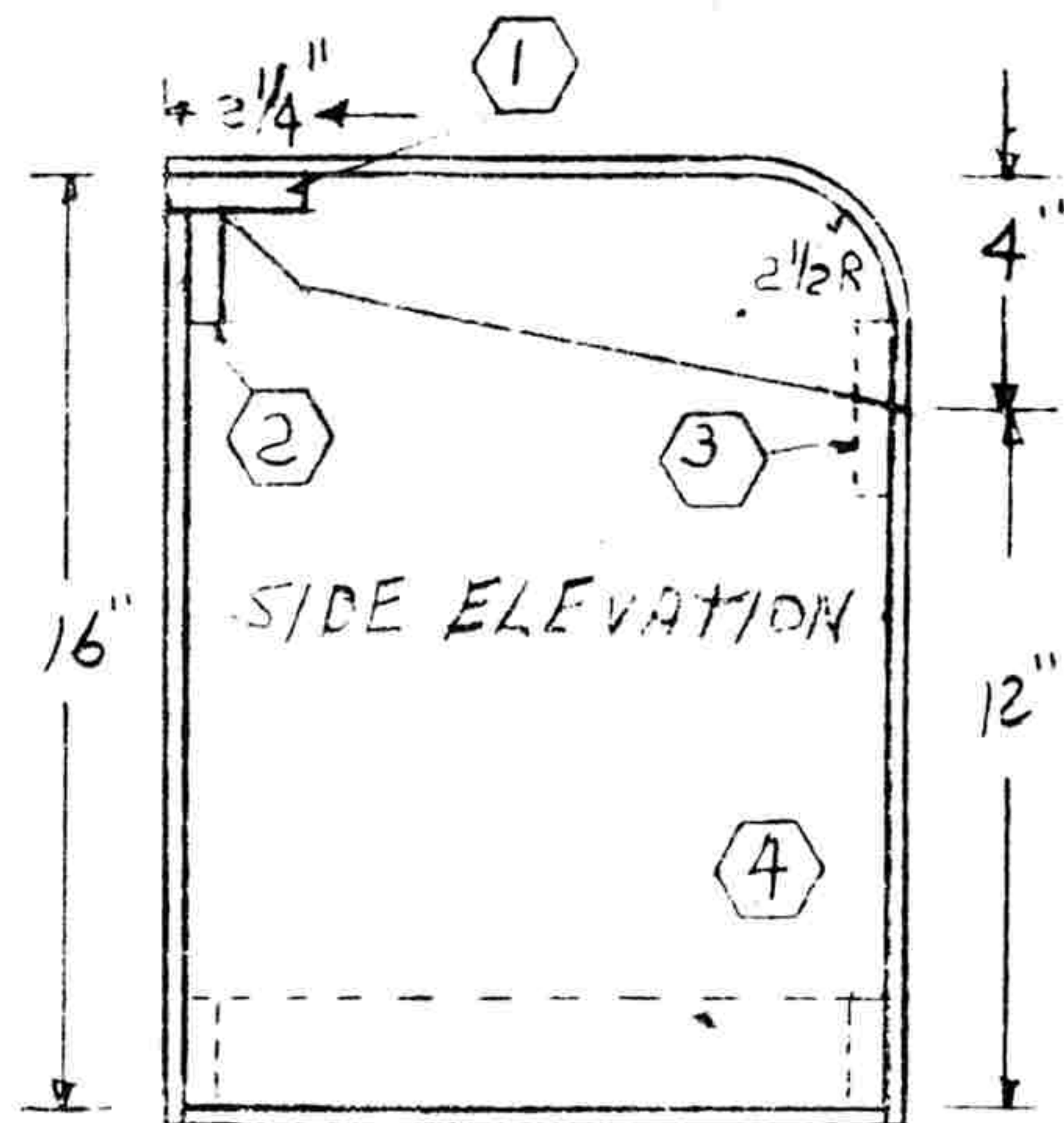
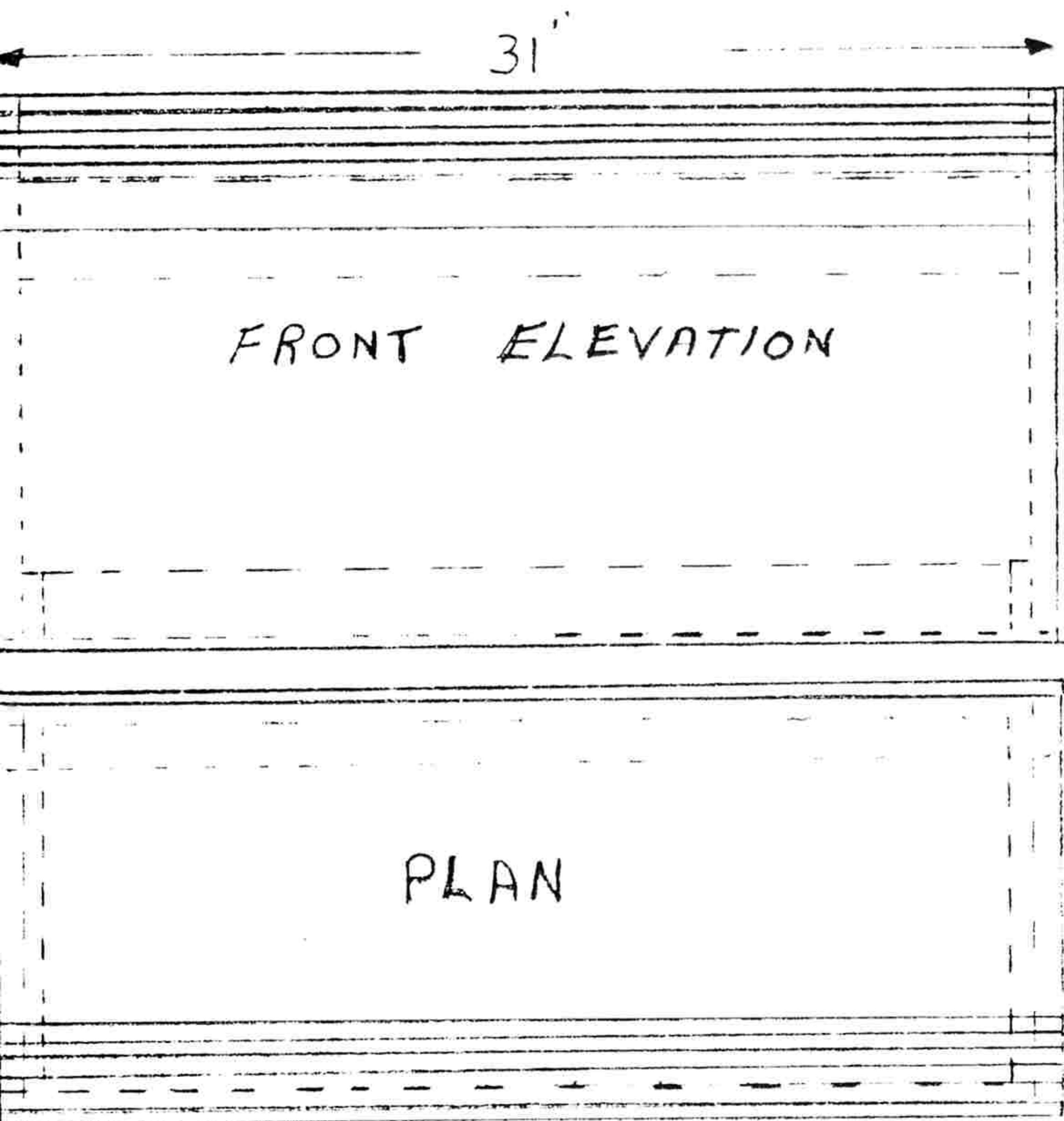

1/8" LEATHER CORNER COVERS

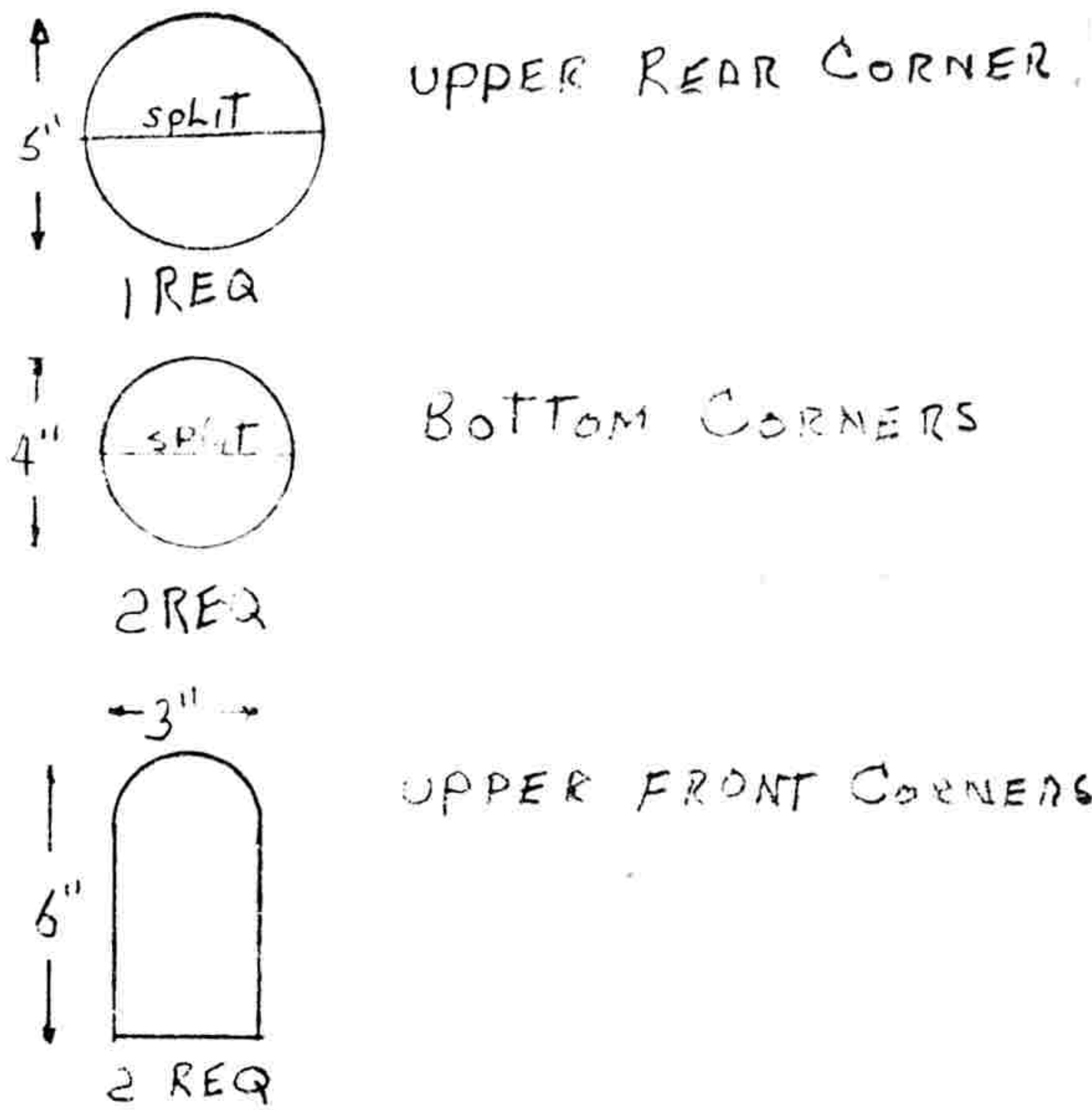

① 5/8 x 2 1/4 x 31" 1 REQ OAK

② 5/8 x 2 x 31 1 REQ OAK

③ 5/8 x 1 1/2 x 29 3/4 2 REQ OAK

STRAPS
1/8 x 2 x 42 2 REQ

④ 5/8 x 2 x 12 2 REQ

④ 5/8 x 2 x 28 1/2 2 REQ

1/4" Plywood
3 PCS REQ
1 - 12 x 31 = BOTTOM
1 - 12 1/4 x 31 = FRONT
1 - 15 5/8 x 31 = BACK

Top 1/8" Plywood
2 PCS REQ 18 x 31 LAMINATED
MUST BE WATER SOAKED TO FORM
TRIM TO FIT AFTER FORMED

Lewis drew these diagrams of the luggage trunk he constructed.

bottom is covered and gimp is placed around the line of tacks to make a finished job.

The flange or lip that is to keep dust from creeping through the joint of lid and trunk will have been removed during this operation and is now ready to be reinstalled. This completes the lining and covering of the trunk proper. (Marshall Lewis simplified the operation by using a single piece of material for the trunk cover as seen in the illustration on page 14. The method used in concealing tacks and seams still apply as described above).

The trunk lid presents a somewhat more complex problem. Here we have two joints composed of a plane curve and an eccentric curve. The joint must be smooth. The plane surface, that is, the end of the lid, and the curving plane, the lid proper, must both be fitted smoothly.

In fitting the covering material to the trunk lid, first coat the lid proper with Contact Spray Glue, applying none to the ends. Place the covering material smoothly on the coated lid, allowing an overhang at each end piece. Let the glue dry.

Then draw the overhanging material down flat or, the end piece, and up under the edge of the end piece, tacking it securely inside the end piece. With scissors, snip along the curving edge of the end piece until the scissors reach the straight edge of the top. Glue the covering material to the end piece flat and smooth. Figure 20 A and B, shows the operation and the completed result.

The job is still not quite finished. The finish is obtained by the use of the leather corners shown in Figures 1, 2 and 3. These are now applied. They are made of light strap leather, of oil-tanned or finished leather matching or contrasting with the covering material. They are held in place by nickel-headed upholstery nails. They serve to conceal raw edges and give a touch of distinction to the job.

The straps which almost encircle the trunk are two-inches wide and beaded. These are fastened with screws to the rear bottom of the trunk and to the front bottom in like manner. If a buckle is added to each strap, it is very important that the buckle-end and the tongue-end line up

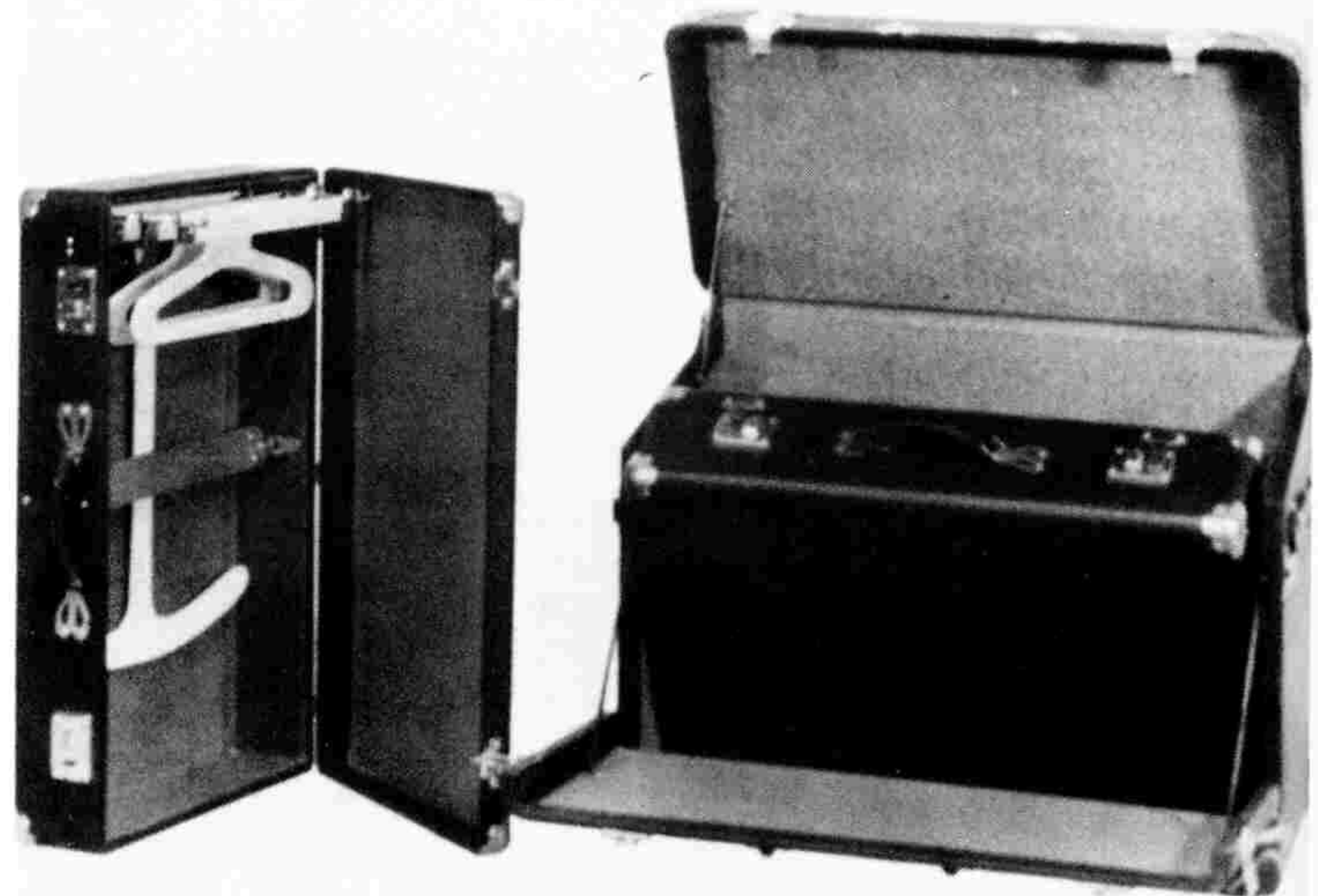
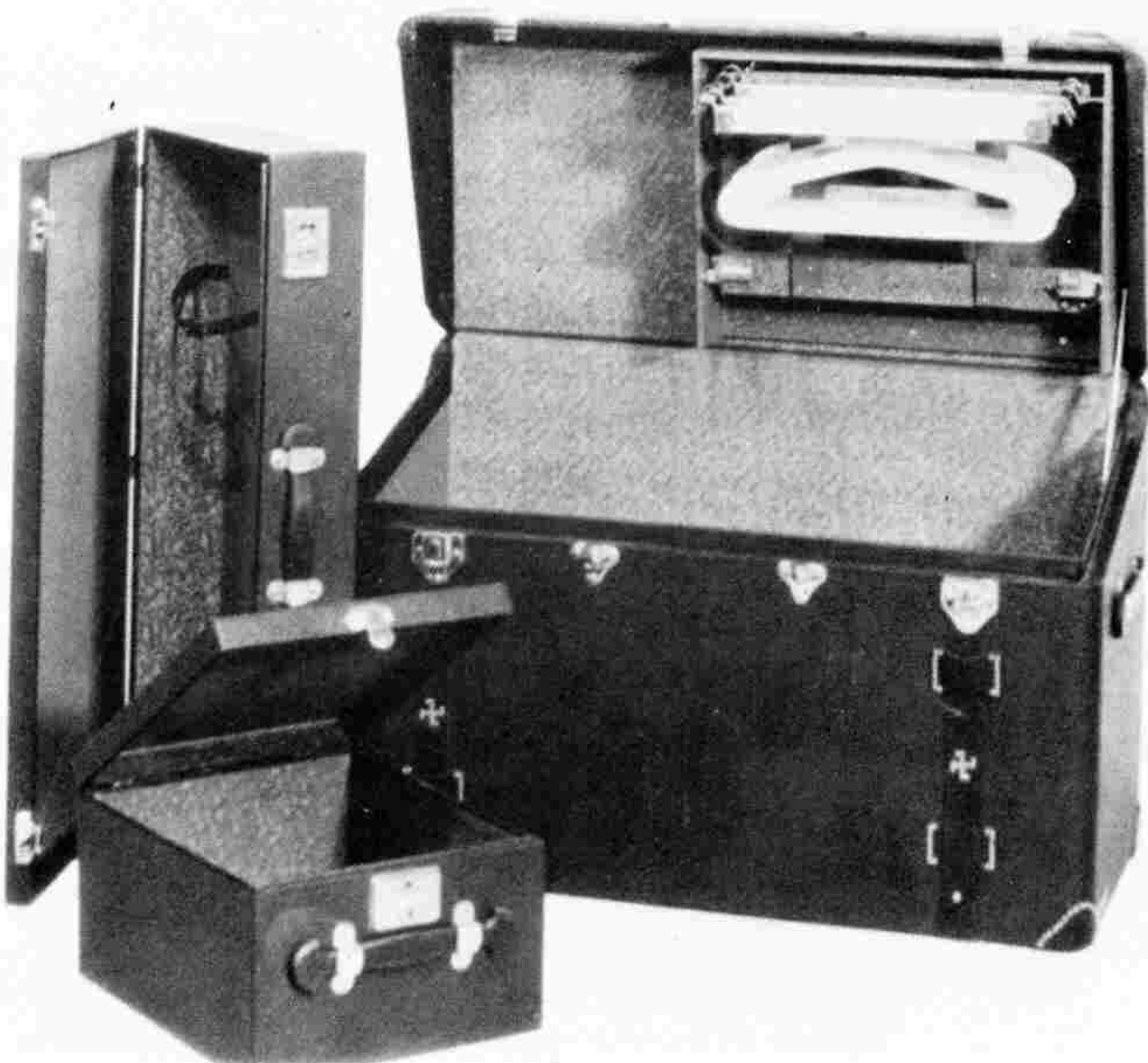
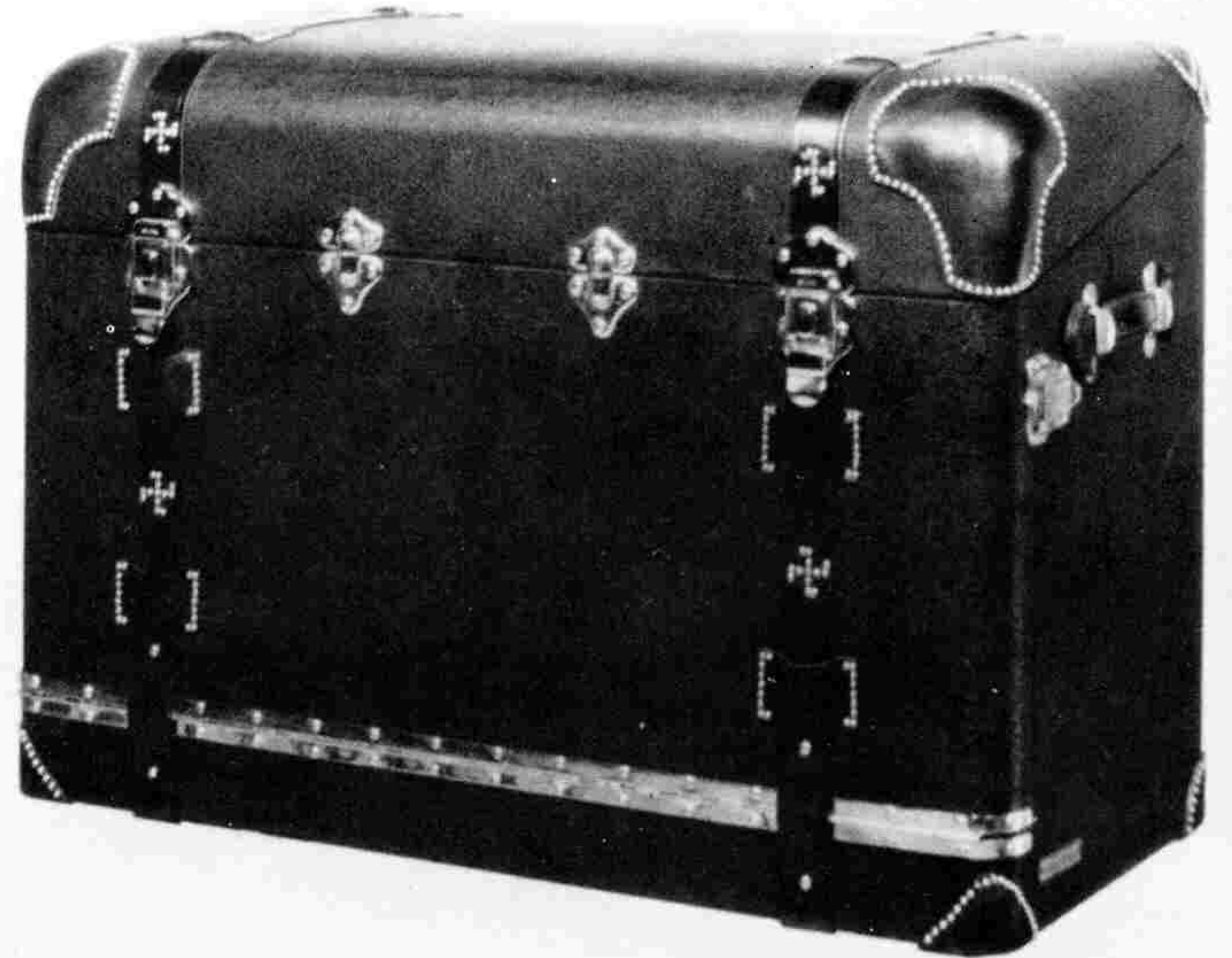
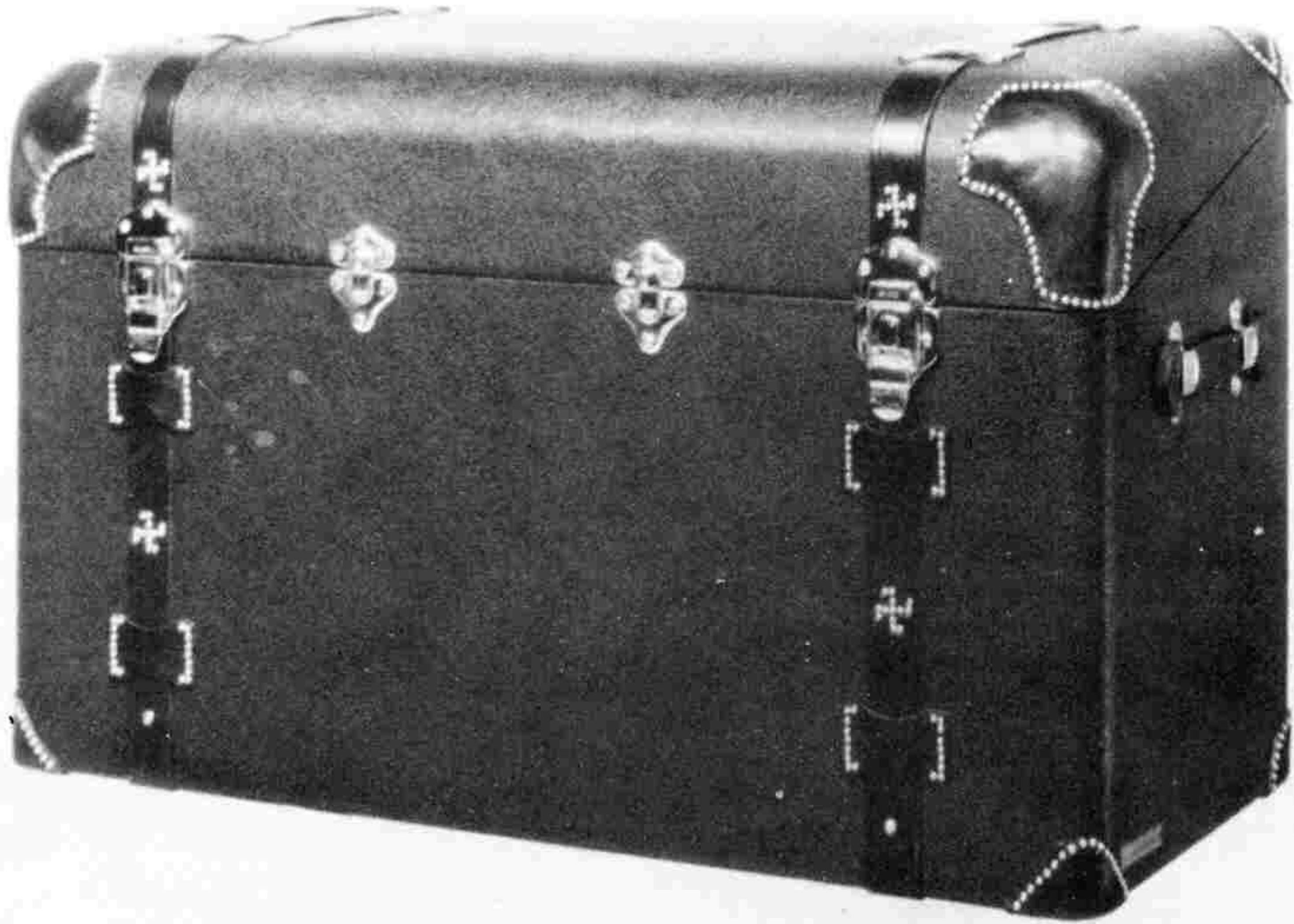

Fancy trunks were fitted with luggage and had elaborate details . . .

. . . These two models were made by Standard Safety Corp. in 1929.

perfectly, otherwise a crooked strap at the point of buckling will result.

The leather end-lifts come next. They are fashioned from the same leather as that used in reinforcing the corners and in making the straps. They are held in place by special handle loops which are screwed in to place as shown in Figure 2. The dimensions of the strap lifts are also shown in that figure.

Now the lid is set in place over the dust flange and the position of the hinges are marked. A 5/8-inch piano-type stainless steel hinge, extending for the length of the trunk and the lid, is to be desired for ease of installation and for ease of operation as well as for durability. The hinges are attached with screws to the stretchers in the trunk and in the lid.

Last of all comes the installation of the toggle latches and the lock, if a separate lock is used. ●

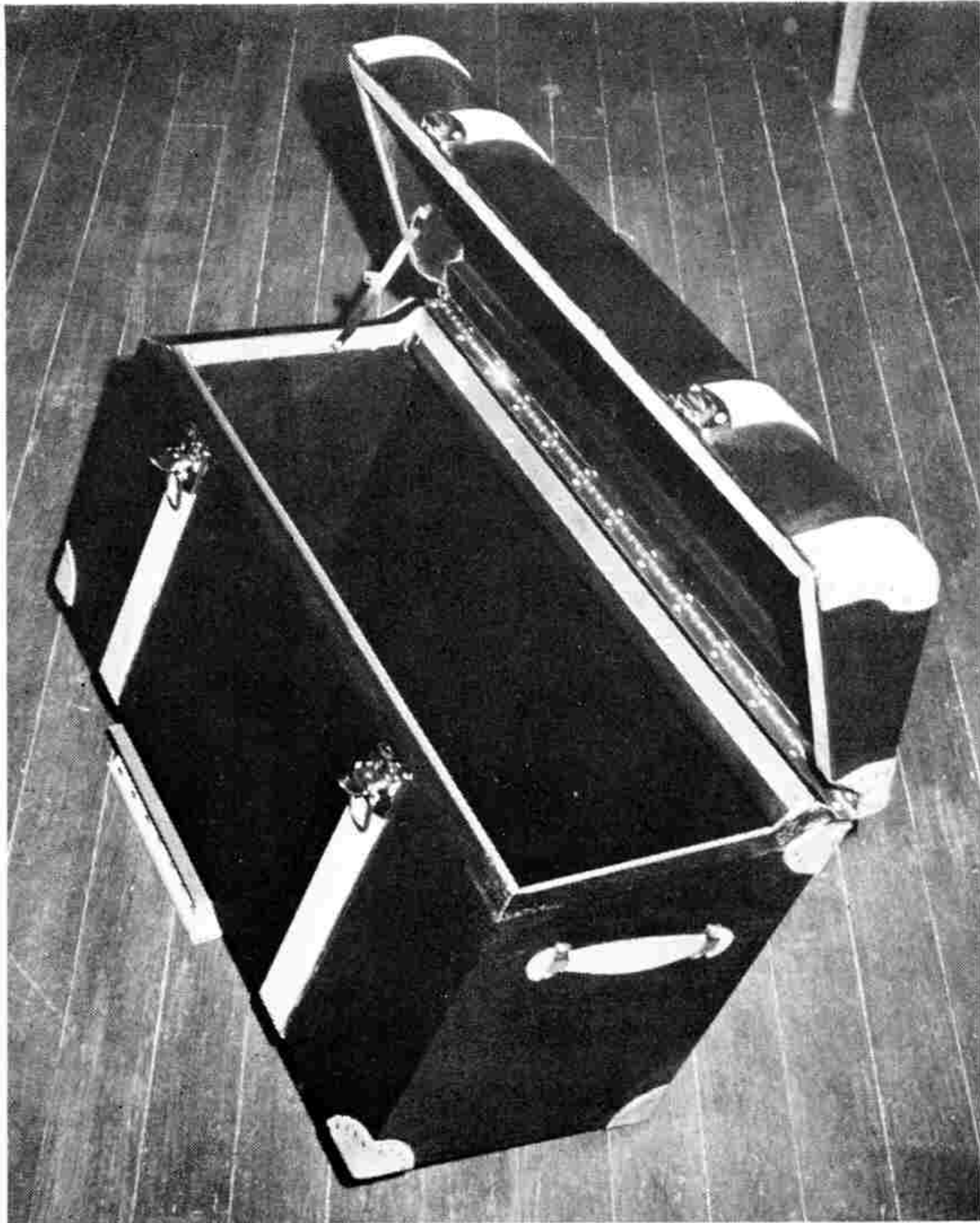

Inside view of Lewis luggage trunk.



Nicely finished off and installed on the rear luggage rack. Leather corners and straps are tan and photograph very light against dark material used. Shoe dye can be applied to tone down leather to match if desired.

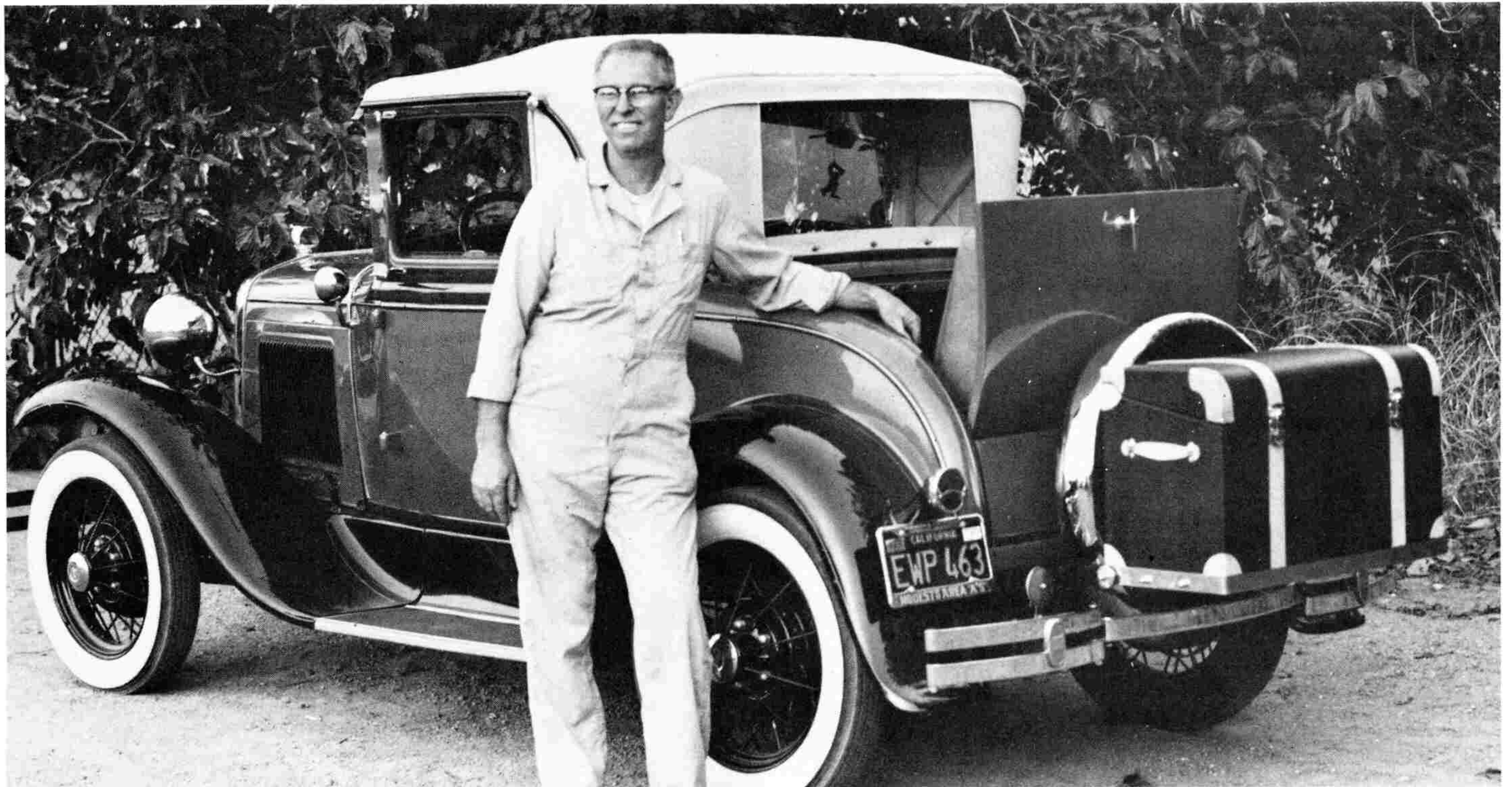

Featured technical author, Marshall Lewis, of Empire, California. Installed at the rear of his prize 1930 Model A Sport Coupe is the experimental luggage trunk which he built to test the plans of a 1929 technical writer. Now you can build one!